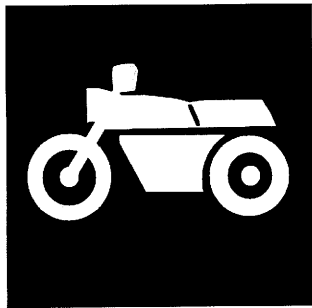


**YAMAHA**



**PARTS  
CATALOGUE**

**YZ125LC'96 (4SS1) EUROPE**

**YZ125H (4SS2) U.S.A., CANADA, S.AFRICA**

**YZ125'96 (4SS3) JAPAN**

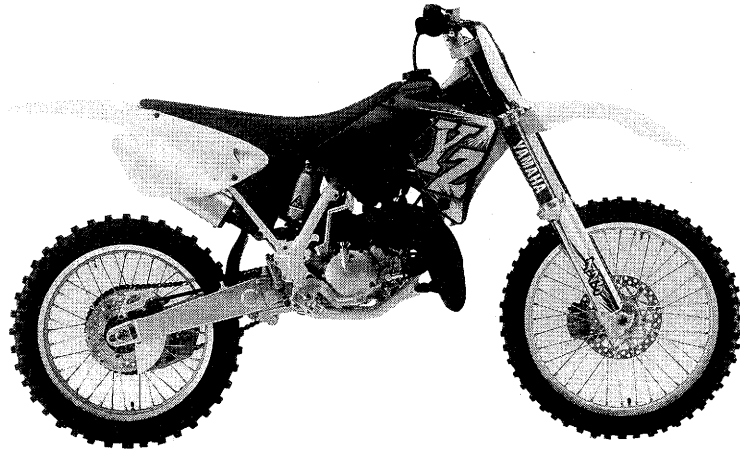
**YZ125H (4SS4) OCEANIA**

---

164SS-100E1

**YAMAHA**  
**GENUINE**  
Parts & Accessories





**A3**



## FOREWORD

This Parts Catalogue is related to the parts for the model(s) in the below frame. When you are ordering replacement parts, please refer to this Parts Catalogue and quote both part numbers and part names correctly.

YZ125LC'96(4SS1), YZ125H(4SS2, 4SS4), YZ125'96(4SS3)

1. Modifications or additions which have been made after issue of the Parts Catalogue will be announced in the Yamaha Parts News.  
It is advisable that you make necessary corrections to the Parts Catalogue according to the Yamaha Parts News.

### 2. Abbreviations

The following abbreviations are used in this Parts Catalogue.

- "UR" Use specified parts number.
- "UN" Use as many as needed.
- "AP" Alternate Parts
- "LM" Local Made (Parts need to be ordered locally)
- "F#" Frame No. (Applicable machine No.)

3. Parts, which are to be supplied in an assembly, are listed with a dot (.) in front of the part name as shown below.

#### EXAMPLE

- CARBURETOR ASSY
- . JET, PILOT
- . NOZZLE, MAIN

### 4. Number of component for assembly

The numeral appearing to the right of each component part indicates the quantity of parts for each assembly unit.

#### EXAMPLE

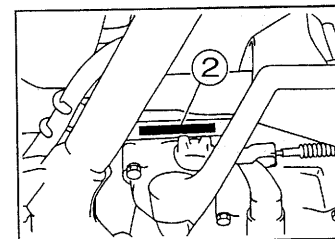
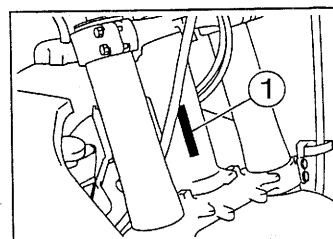
PART NO.	DESCRIPTION	Q'TY	REMARKS
2F5-83310-60	FRONT FLASHER LIGHT ASSY	2	
115-83311-60	. BULB (6V-18W)	1	

5. Applicable colors of graphics are represented in the "REMARKS" as shown below.

PART NO.	DESCRIPTION	Q'TY	REMARKS
2N4-24110-00-X5	FUEL TANK COMP.	1	MAXIM RED
3J1-24240-10	. GRAPHIC, FUEL TANK	1	for MXR

6. Applicable Serial No. and Color Code

4SS1	①	Frame Serial No.	4SS-000101	~
	②	Engine Serial No.	4SS-000101	~
4SS2	①	Frame Serial No.	4SS-005101	~
	②	Engine Serial No.	4SS-005101	~
4SS3	①	Frame Serial No.	4SS-013101	~
	②	Engine Serial No.	4SS	~
4SS4	①	Frame Serial No.	4SS-015101	~
	②	Engine Serial No.	4SS-015101	~



Color Code	Color Name	Abbreviation
0206	PURPLISH WHITE SOLID 1	PWS1

7. Note that the illustrations are for reference in finding parts numbers, not to be used for assembling. When assembling, please use the applicable service manual.
8. The asterisk (\*) before a reference number indicates modification items after the first edition.

# CONTENTS

## ENGINE

Cylinder Head .....	B2~B3
Governor .....	B4
Crankshaft, Piston .....	B5
Water Pump .....	B6
Radiator, Hose .....	B7
Intake .....	B8
Carburetor .....	B9~B10
Exhaust .....	B11
Crankcase .....	B12
Crankcase Cover 1 .....	B13
Starter .....	B14
Clutch .....	B15
Transmission .....	C2~C3
Shift Cam, Fork .....	C4
Shift Shaft .....	C5

## CHASSIS

Frame .....	C6
Fender .....	C7
Side Cover .....	C8
Rear Arm .....	C9~C10
Rear Suspension .....	C11
Steering .....	C12
Front Fork .....	C13~C15
Fuel Tank .....	D2
Seat .....	D3
Front Wheel .....	D4
Front Brake Caliper .....	D5
Rear Wheel .....	D6~D7

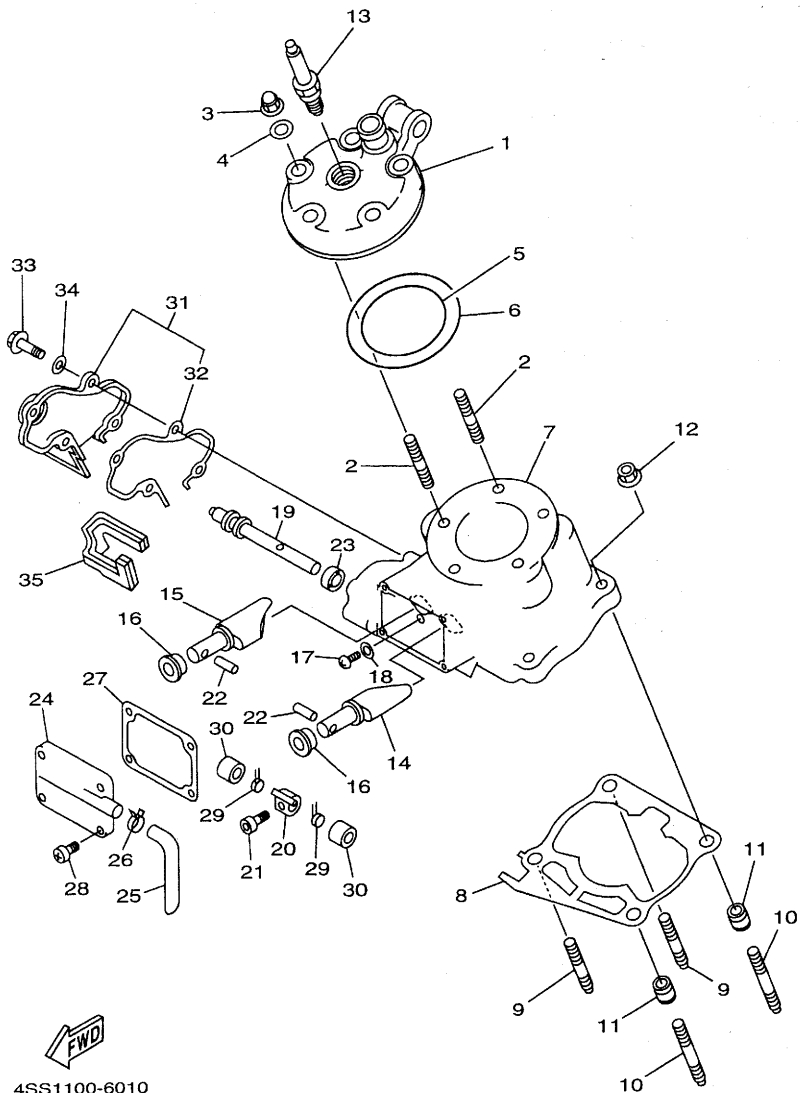
Rear Brake Caliper .....	D8
Steering Handle, Cable .....	D9
Front Master Cylinder .....	D10
Stand, Footrest .....	D11
Rear Master Cylinder .....	D12
Generator .....	D13
Handle Switch, Lever .....	D14
Electrical 1 .....	D15
Alternate (Chassis) .....	E2
Optional Parts 1 .....	E3

## INDEX

Numerical Index .....	M1~M3
-----------------------	-------

FIG. 1 CYLINDER HEAD

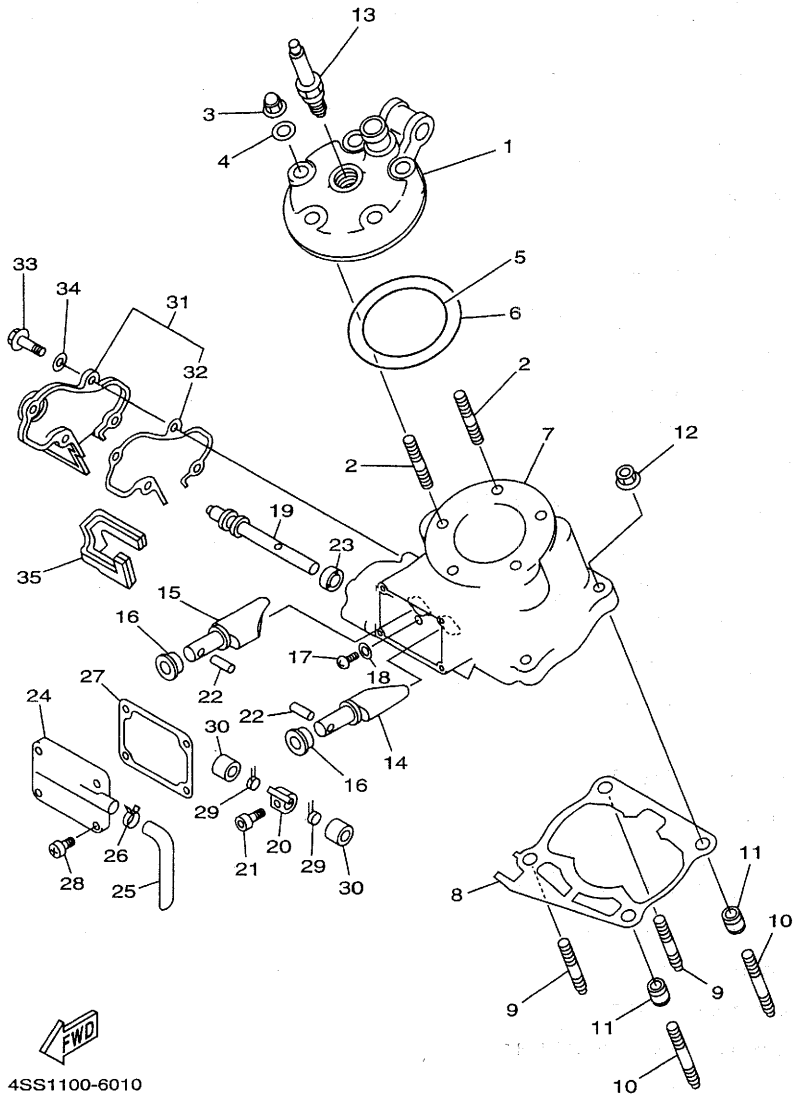
REF. NO.	PART NO.	DESCRIPTION	QTY	REMARKS
1	4SS-11111-00	HEAD, CYLINDER 1	1	
2	90116-08394	BOLT, STUD	5	
3	90176-08026	NUT, CROWN	5	
4	90201-08087	WASHER, PLATE	5	
5	93210-63442	O-RING	1	
6	93210-90785	O-RING	1	
7	4SS-11311-00	CYLINDER 1	1	
8	4JY-11351-00	GASKET, CYLINDER	1	
9	90116-08318	BOLT, STUD	2	
10	90116-08388	BOLT, STUD	2	
11	99510-10114	PIN, DOWEL	2	
12	90179-08491	NUT	4	
13	94702-00325	PLUG, SPARK (NGK B9EG)	1	UR
	94702-00324	PLUG, SPARK (NGK BR9EG)	1	UR FOR CANADA, S.AFRICA
	94703-00325	PLUG, SPARK (NGK B9EG)	1	UR FOR JAPAN
14	4SS-1131A-00	VALVE 1	1	
15	4SS-1132A-00	VALVE 2	1	
16	4JY-1131E-00	HOLDER 1	2	
17	98907-05010	SCREW, BIND	2	
18	90201-057H5	WASHER, PLATE	2	
19	4SS-1131V-00	SHAFT 1	1	
20	4SS-11832-00	LEVER, LINK	1	
21	91317-04008	BOLT, SOCKET HEAD	1	
22	93604-18100	PIN, DOWEL	2	
23	93104-08040	OIL SEAL	1	
24	4SS-1131M-00	COVER	1	
25	4JY-11166-00	PIPE, BREATHER 1	1	
26	90467-13062	CLIP	1	



4SS1100-6010

FIG. 1 CYLINDER HEAD

REF. NO.	PART NO.	DESCRIPTION	Q'TY	REMARKS
27	4JY-11354-01	GASKET	1	
28	98907-05016	SCREW, BIND	4	
29	90508-147A7	SPRING, TORSION	2	
30	90387-08785	COLLAR	2	
31	4JY-11991-00	HOUSING 1	1	
32	4JY-11993-00	GASKET	1	
33	97007-05016	BOLT	4	
34	92907-05600	WASHER, PLATE	4	
35	4JY-11995-00	SEAL, HOUSING	1	



4SS1100-6010



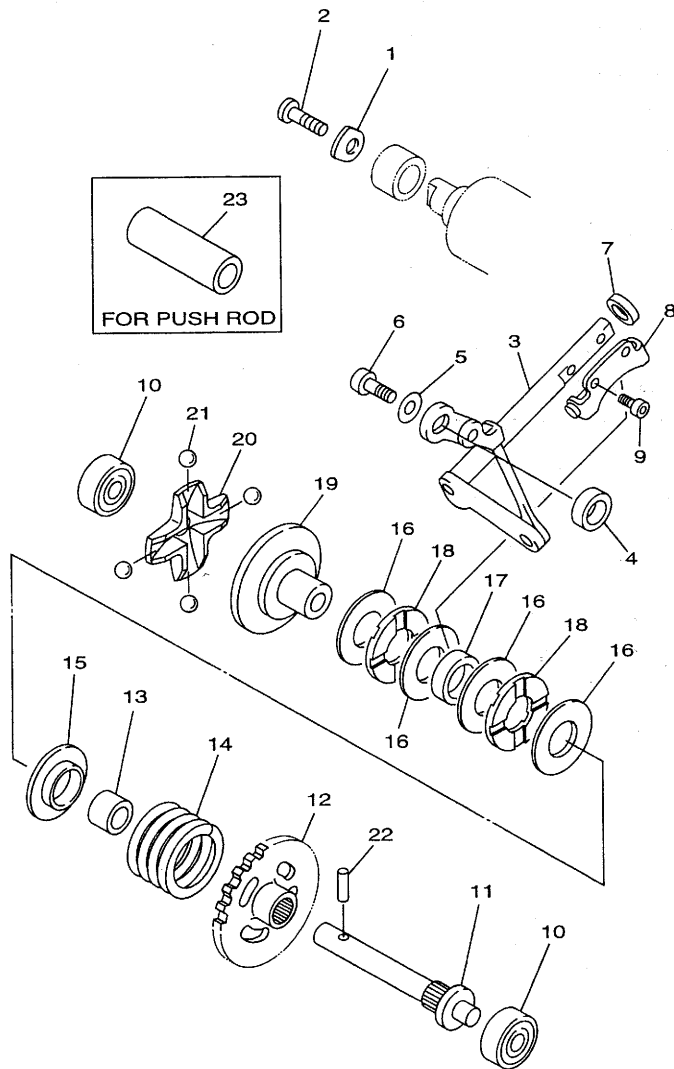


FIG. 2 GOVERNOR

REF. NO.	PART NO.	DESCRIPTION	Q'TY	REMARKS
1	4JY-11915-01	PLATE, THRUST 1	1	
2	98507-05012	SCREW, PAN HEAD	1	
3	4SS-11990-00	PUSH ROD ASSY	1	
4	90387-085E1	COLLAR	1	
5	90201-057H5	WASHER, PLATE	1	
6	97007-05012	BOLT	1	
7	93104-08040	OIL SEAL	1	
8	3JE-11922-01	FORK, GOVERNOR	1	
9	91317-04006	BOLT, SOCKET HEAD	2	
10	93300-60814	BEARING (608M4ML01)	2	NMB
11	5X4-11921-02	SHAFT, GOVERNOR	1	
12	24X-11953-01	GEAR, GOVERNOR	1	
13	90560-08213	SPACER	1	
14	90501-30742	SPRING, COMPRESSION	1	
15	5X4-11952-00	PLATE	1	
16	90201-154E9	WASHER, PLATE	4	
17	90387-152F2	COLLAR	1	
18	93340-21505	BEARING, THRUST	2	
19	5X5-11912-01	RETAINER, WEIGHT	1	
20	5X5-11911-01	RETAINER	1	
21	93521-64032	BALL	4	
22	93603-14179	PIN, DOWEL	1	
23	90387-107T9	COLLAR	1	AP FOR PUSH ROD

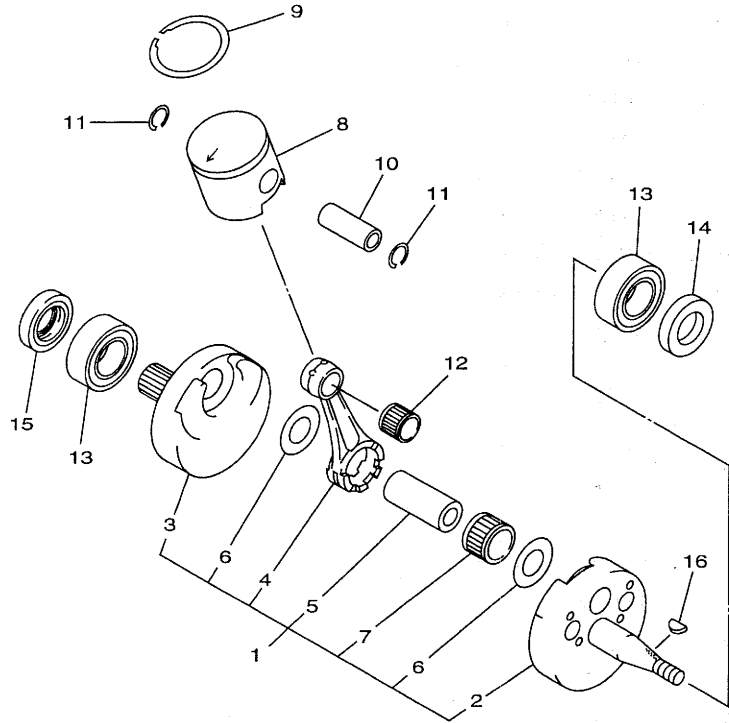


4SS1100-6020

**B4**

FIG. 3 CRANKSHAFT. PISTON

REF. NO.	PART NO.	DESCRIPTION	Q'TY	REMARKS
1	4SS-11400-00	CRANKSHAFT ASSY	1	
2	4SS-11410-00	.CRANKSHAFT	1	
3	4SS-11420-00	.CRANKSHAFT	1	
4	4PE-11651-01	.ROD, CONNECTING	1	
5	3JD-11681-01	.PIN, CRANK 1	1	
6	90209-22248	.WASHER	2	
7	93310-522P7	.BEARING, CYLINDRICAL	1	
8	4JY-11631-02-A0	PISTON (STD)	1	UR
	4JY-11631-02-B0	PISTON (STD)	1	UR
	4JY-11631-02-C0	PISTON (STD)	1	UR
	4JY-11631-02-D0	PISTON (STD)	1	UR
9	4JY-11611-00	RING, PISTON	1	
10	4PE-11633-00	PIN, PISTON	1	
11	93450-17129	CIRCLIP	2	
12	93310-216L2	BEARING, CYLINDRICAL	1	
13	93306-37204	BEARING (63/22SH2-9TC4)	2	KOYO
14	93102-22363	OIL SEAL	1	
15	93103-32099	OIL SEAL	1	
16	90280-03017	KEY, WOODRUFF	1	



4SS1100-6030

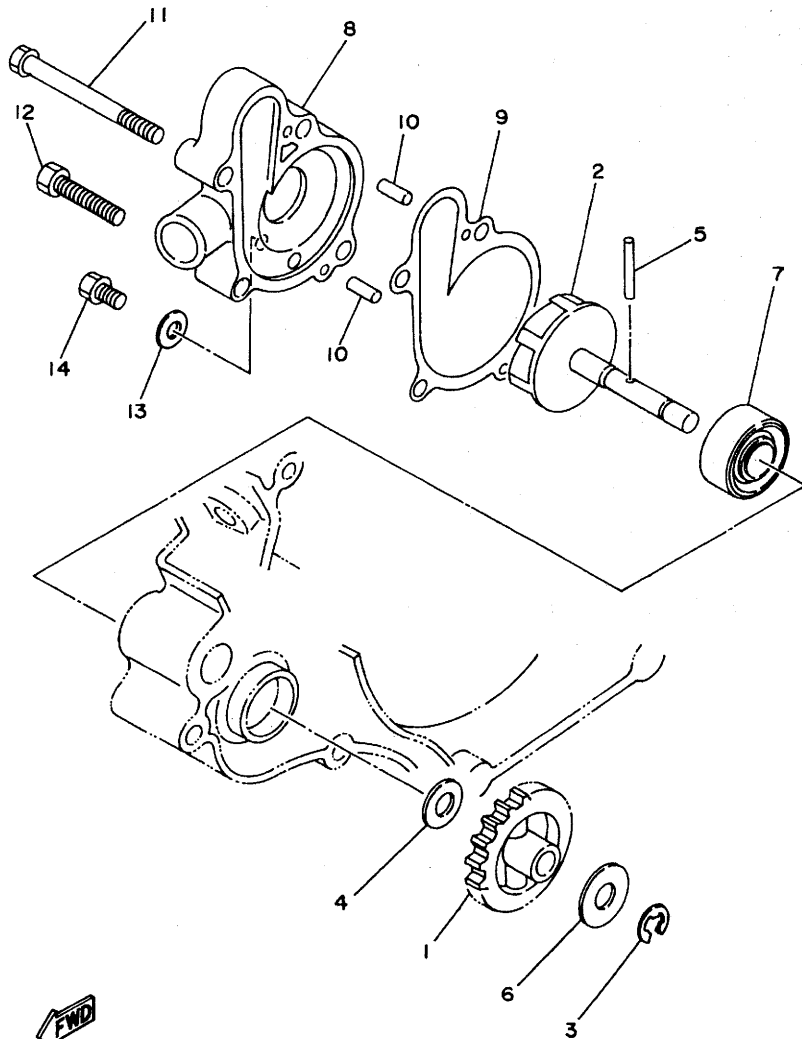


FIG. 4 WATER PUMP

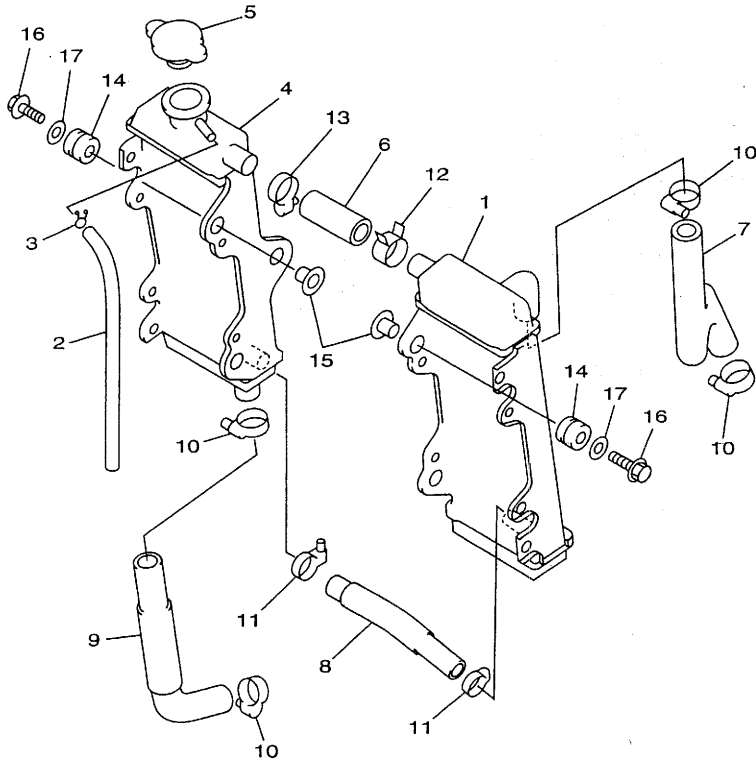
REF. NO.	PART NO.	DESCRIPTION	Q'TY	REMARKS
1	4SS-12459-00	GEAR, IMPELLER SHAFT	1	
2	1LX-12450-00	IMPELLER SHAFT ASSY	1	
3	99080-07600	CIRCLIP	1	
4	90201-08512	WASHER, PLATE	1	
5	93603-22028	PIN, DOWEL	1	
6	90201-08784	WASHER, PLATE	1	
7	93103-10168	OIL SEAL	1	
8	4JY-12422-00	COVER, HOUSING	1	
9	4JY-12428-00	GASKET, HOUSING COVER 2	1	
10	93604-10011	PIN, DOWEL	2	
11	95027-06065	BOLT, FLANGE	2	
12	95027-06030	BOLT, FLANGE	2	
13	90430-06014	GASKET	1	
14	95027-06010	BOLT, FLANGE	1	



4JY1100-4040

**B6**

FIG. 5 RADIATOR, HOSE



REF. NO.	PART NO.	DESCRIPTION	Q'TY	REMARKS
1	4SS-1240A-00	RADIATOR ASSY	1	
2	91A20-05080	TUBE, FLEXIBLE VINYL	1	
3	90467-09006	CLIP	1	
4	4SS-12461-00	RADIATOR ASSY	1	
5	22W-12462-00	CAP, RADIATOR	1	
6	4SS-12481-00	PIPE 1	1	
7	4SS-12482-00	PIPE 2	1	
8	4SS-12483-00	PIPE 3	1	
9	4SS-12484-00	PIPE 4	1	
10	90450-28014	HOSE CLAMP ASSY	4	
11	90450-22052	HOSE CLAMP ASSY	2	
12	90467-21068	CLIP	1	
13	90450-25037	HOSE CLAMP ASSY	1	
14	90480-15528	GROMMET	6	
15	90387-0700G	COLLAR	6	
16	95027-06030	BOLT, FLANGE	6	
17	90201-063J2	WASHER, PLATE	6	



4SS1100-6050

B7

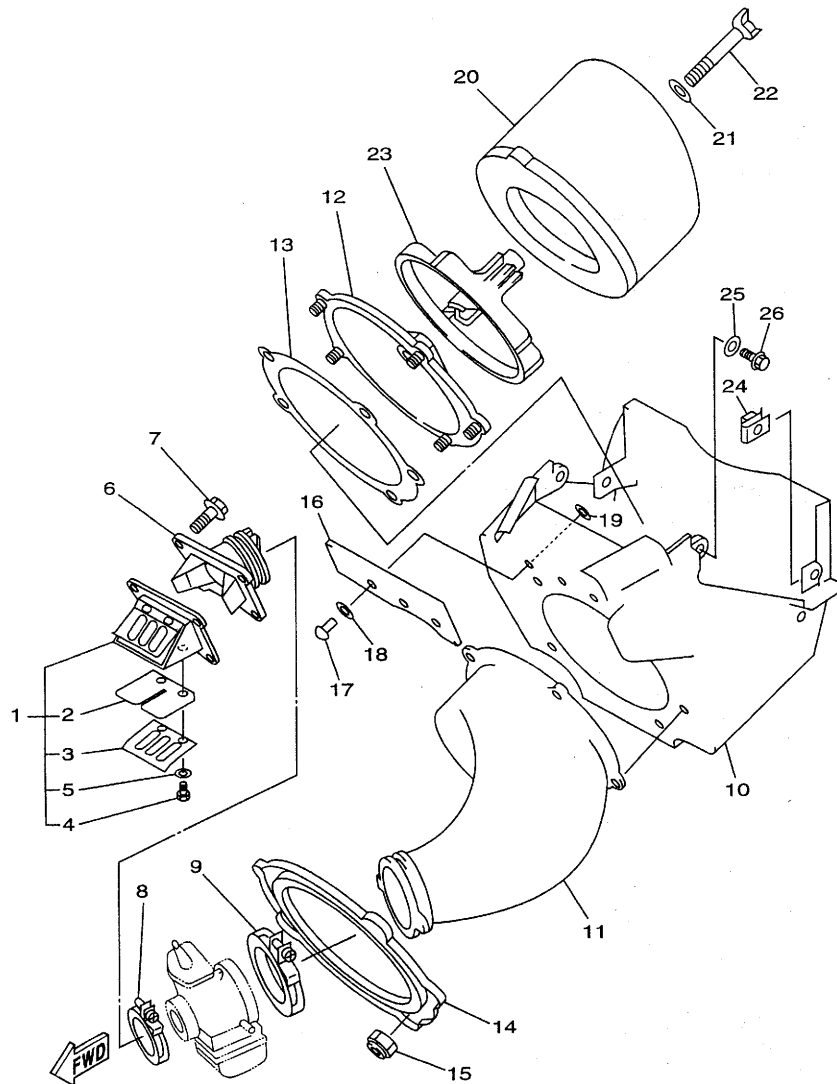
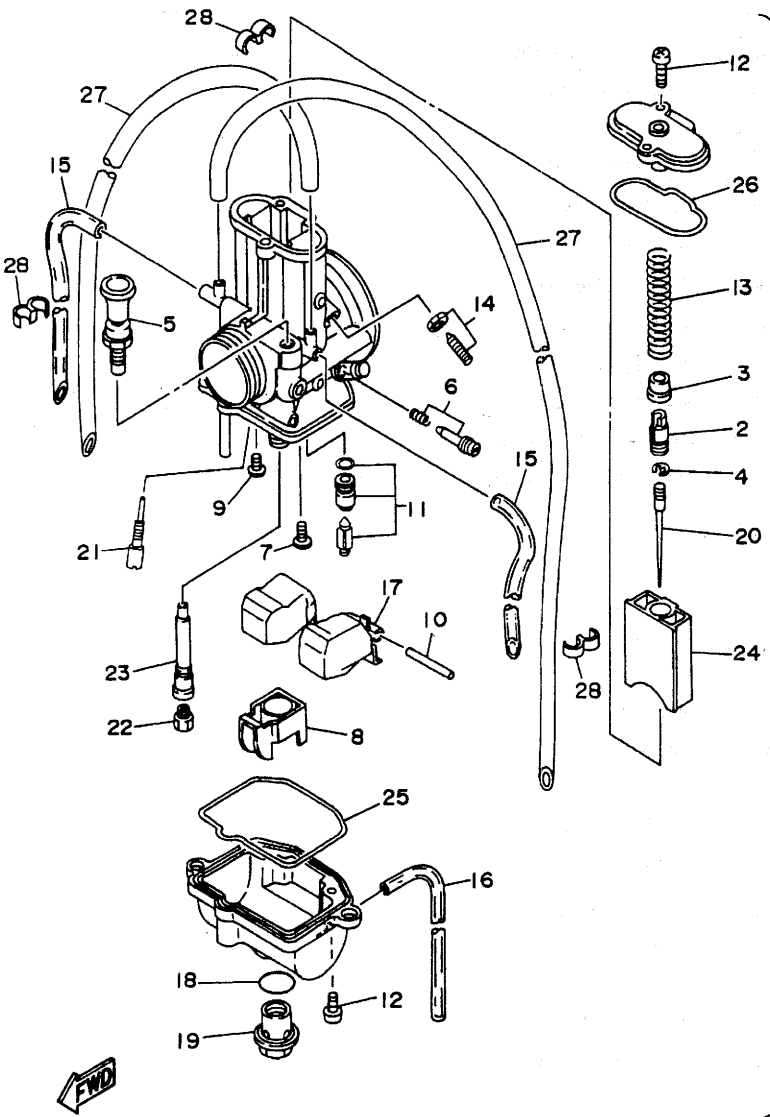


FIG. 6 INTAKE

REF. NO.	PART NO.	DESCRIPTION	Q'TY	REMARKS
1	4SS-13610-00	REED VALVE ASSY	1	
2	4SS-13613-00	.REED, VALVE	2	
3	4JY-13616-00	.STOPPER, REED VALVE	2	
4	98507-03008	.SCREW, PAN HEAD	6	
5	92990-03100	.WASHER, SPRING	6	
6	4PE-13565-00	JOINT, CARBURETOR	1	
7	95027-06020	BOLT, FLANGE	4	
8	90450-51070	HOSE CLAMP ASSY	1	
9	90450-70072	HOSE CLAMP ASSY	1	
10	4SS-14401-00	AIR CLEANER CASE ASSY	1	
11	4SS-14453-00	JOINT, AIR CLEANER 1	1	
12	3JD-14459-00	HOLDER, GUIDE	1	
13	3JD-14462-00	SEAL	1	
14	3JD-14477-00	PLATE	1	
15	95617-05100	NUT, U	5	
16	4SS-14417-00	COVER 1	1	
17	90267-32119	RIVET, BLIND	3	
18	90201-03644	WASHER, PLATE	3	
19	92907-03200	WASHER	3	
20	4SS-14451-00	ELEMENT, AIR CLEANER	1	
21	90209-06096	WASHER	1	
22	90122-06035	BOLT, WING	1	
23	3JD-14458-00	GUIDE	1	
24	90183-06023	NUT, SPRING	4	
25	90201-061A5	WASHER, PLATE	2	
26	90105-06553	BOLT, WASHER BASED	2	

4SS1100-6060



4PE1100-5070

FIG. 7 CARBURETOR

REF. NO.	PART NO.	DESCRIPTION	Q'TY	REMARKS
1	4SS-14101-00	CARBURETOR ASSY 1	1	
2	4PE-14261-00	.HOLDER	1	
3	4PE-14194-00	.RING	1	
4	256-14919-00	.CLIP	1	
5	3JE-14171-00	.PLUNGER, STARTER	1	
6	3JD-14104-00	.AIR SCREW SET	1	
7	1FN-14565-00	.SCREW	1	
8	4PE-14243-00	.PLATE	1	
9	98507-04008	.SCREW, PAN HEAD	1	
10	353-14186-00	.PIN, FLOAT	1	
11	4PE-14107-38	.NEEDLE VALVE SET	1	
12	98517-04012	.SCREW, PAN HEAD	3	
13	4PE-14131-00	.SPRING, THROTTLE VALVE	1	
14	4PE-14103-00	.THROTTLE SCREW SET	1	
15	2J2-14196-00	.PIPE	2	
16	3X3-14197-00	.PIPE	1	
17	4PE-14185-00	.FLOAT	1	
18	3JE-14561-00	.O-RING	1	
19	3XK-14115-00	.PLUG, SCREW	1	
20	5A0-14116-E1	.NEEDLE (6BEG9-69)	1	STD
	5A0-14116-E2	.NEEDLE (6BEG9-67)	1	AP
	5A0-14116-E3	.NEEDLE (6BEG9-68)	1	AP
	5A0-14116-E0	.NEEDLE (6BEG9-70)	1	AP
	5A0-14116-E4	.NEEDLE (6BEG9-71)	1	AP
21	4KM-14142-55	.JET, PILOT (# 55)	1	STD
	4KM-14142-40	.JET, PILOT (# 40)	1	AP
	4KM-14142-45	.JET, PILOT (# 45)	1	AP
	4KM-14142-50	.JET, PILOT (# 50)	1	AP

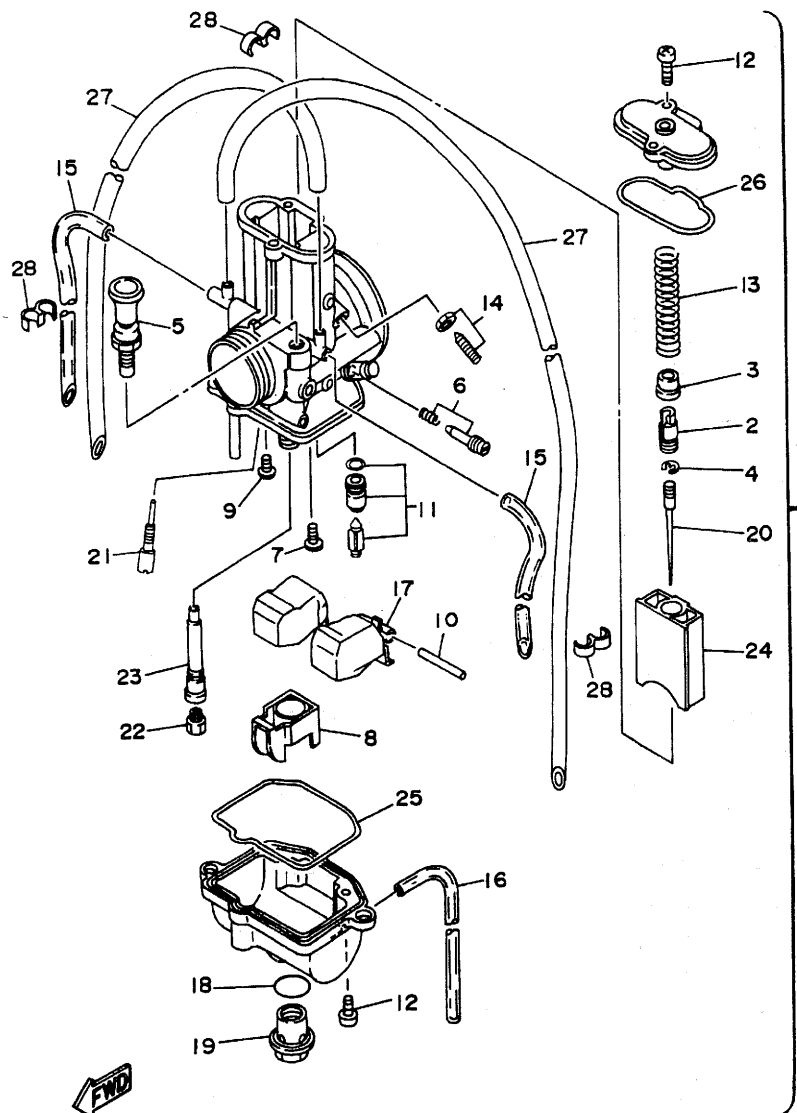


FIG. 7 CARBURETOR

REF. NO.	PART NO.	DESCRIPTION	Q'TY	REMARKS
21	4KM-14142-60	.JET, PILOT (# 60)	1	AP
	4KM-14142-65	.JET, PILOT (# 65)	1	AP
22	137-14143-70	.JET, MAIN (#350)	1	STD
	137-14143-66-A1	.JET, MAIN (#330)	1	AP
	137-14143-68	.JET, MAIN (#340)	1	AP
	137-14143-72	.JET, MAIN (#360)	1	AP
	137-14143-74	.JET, MAIN (#370)	1	AP
23	3TC-14141-S9	.NOZZLE, MAIN (S-9)	1	STD
	3TC-14141-S6	.NOZZLE, MAIN (S-6)	1	AP
	3TC-14141-S7	.NOZZLE, MAIN (S-7)	1	AP
	3TC-14141-S8	.NOZZLE, MAIN (S-8)	1	AP
	3TC-14141-T0	.NOZZLE, MAIN (T-0)	1	AP
24	4SS-14112-50	.VALVE, THROTTLE (C.A 5.0)	1	STD
	4SS-14112-45	.VALVE, THROTTLE (C.A 4.5)	1	AP
	4SS-14112-55	.VALVE, THROTTLE (C.A 5.5)	1	AP
25	4PE-1416A-00	.O-RING	1	
26	4PE-14147-00	.O-RING	1	
27	4PE-14197-00	.PIPE	2	
28	87M-14137-00	.CLIP	3	

4PE1100-5070

**B10**

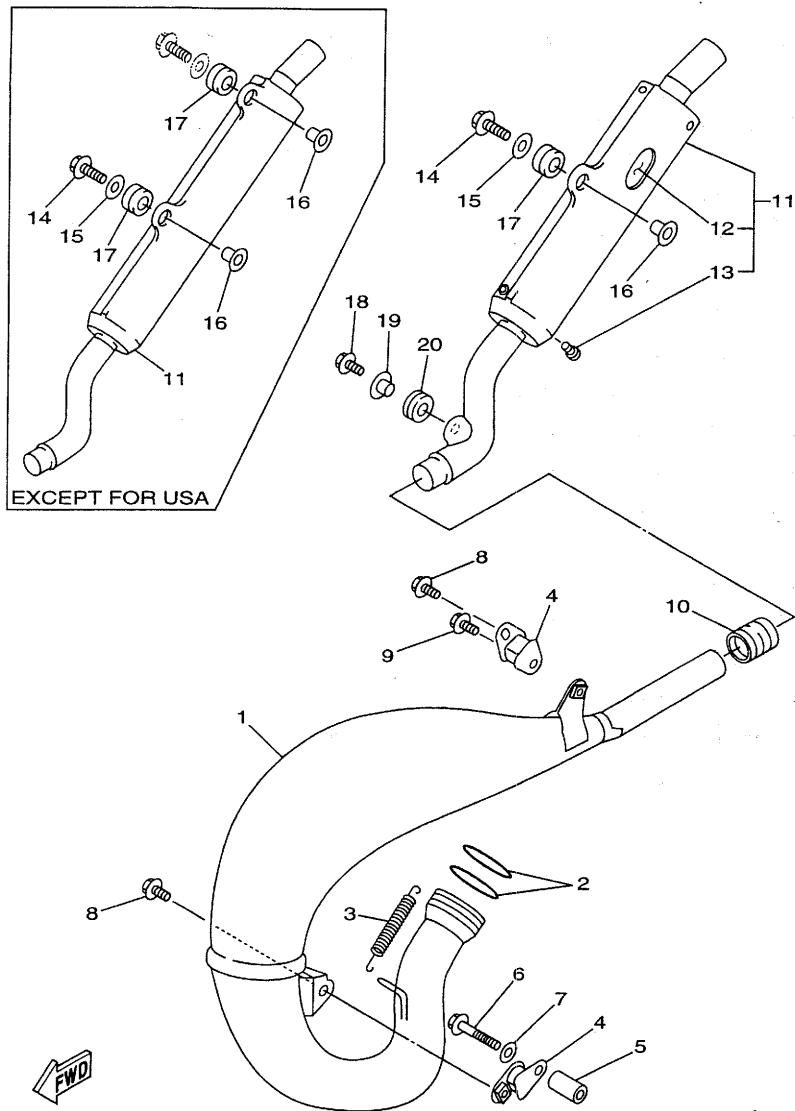


FIG. 8 EXHAUST

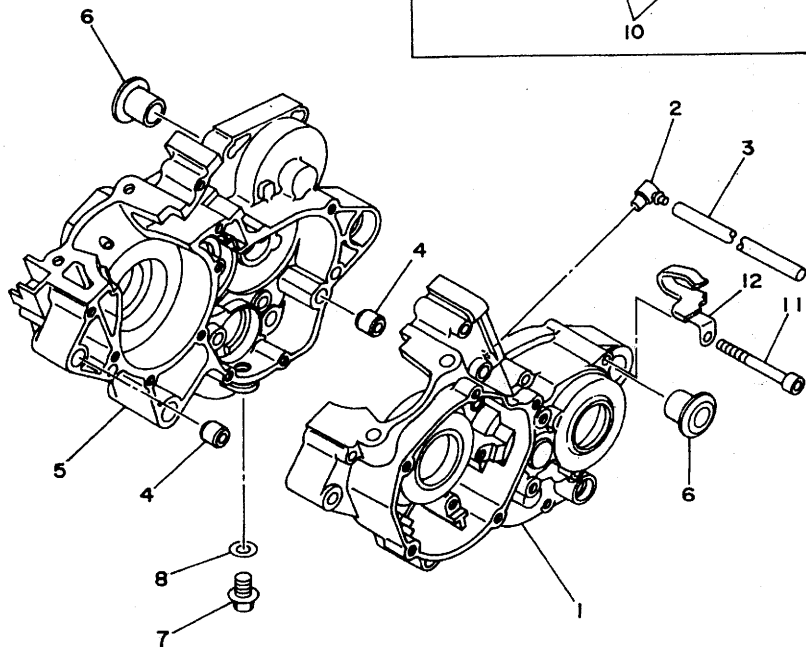
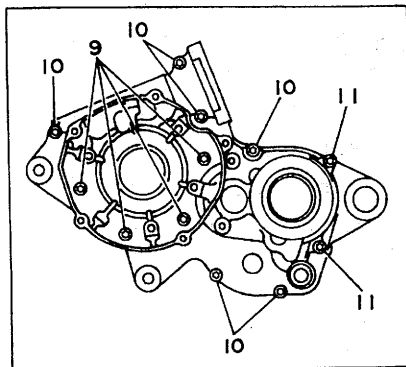
REF. NO.	PART NO.	DESCRIPTION	Q'TY	REMARKS
1	4SS-14610-00	EXHAUST PIPE ASSY 1	1	
2	93210-42728	O-RING	2	
3	90507-20052	SPRING, TENSION	2	
4	565-14771-00	STAY, MUFFLER 1	2	
5	90387-062W7	COLLAR	1	
6	95027-06045	BOLT, FLANGE	1	
7	90201-065F3	WASHER, PLATE	1	
8	95027-06012	BOLT, FLANGE	2	
9	90119-06185	BOLT, WITH WASHER	1	
10	4JY-14615-00	JOINT, EXHAUST 1	1	
11	4SS-14753-00	SILENCER, EXHAUST	1	UR FOR U.S.A
	4SS-14753-10	SILENCER, EXHAUST	1	UR
12	4JY-1469A-02	.FIBER	1	
13	92017-06010	.SCREW	2	
14	95027-06025	BOLT, FLANGE	1	
15	90201-063J2	WASHER, PLATE	1	
16	90387-063G3	COLLAR	1	UR FOR U.S.A
	90387-063G3	COLLAR	2	UR
17	90480-16561	GROMMET	1	UR FOR U.S.A
	90480-16561	GROMMET	2	UR
18	95027-06016	BOLT, FLANGE	1	FOR U.S.A
19	90387-107R6	COLLAR	1	FOR U.S.A
20	90480-10289	GROMMET	1	FOR U.S.A

4SS1100-6080



FIG. 9 CRANKCASE

REF. NO.	PART NO.	DESCRIPTION	QTY	REMARKS
1	4SS-15111-00	CRANKCASE 1	1	
2	353-13115-01	CONNECTOR, SUCTION PIPE	1	
3	90445-08605	HOSE	1	
4	99510-12016	PIN, DOWEL	2	
5	4SS-15121-00	CRANKCASE 2	1	
6	90387-160H4	COLLAR	2	
7	90340-12097	PLUG, STRAIGHT SCREW	1	
8	90430-12227	GASKET	1	
9	91317-06045	BOLT, SOCKET HEAD	4	
10	91317-06055	BOLT, SOCKET HEAD	6	
11	91317-06070	BOLT, SOCKET HEAD	2	
12	90465-08336	CLAMP	1	



4JY1100-4090

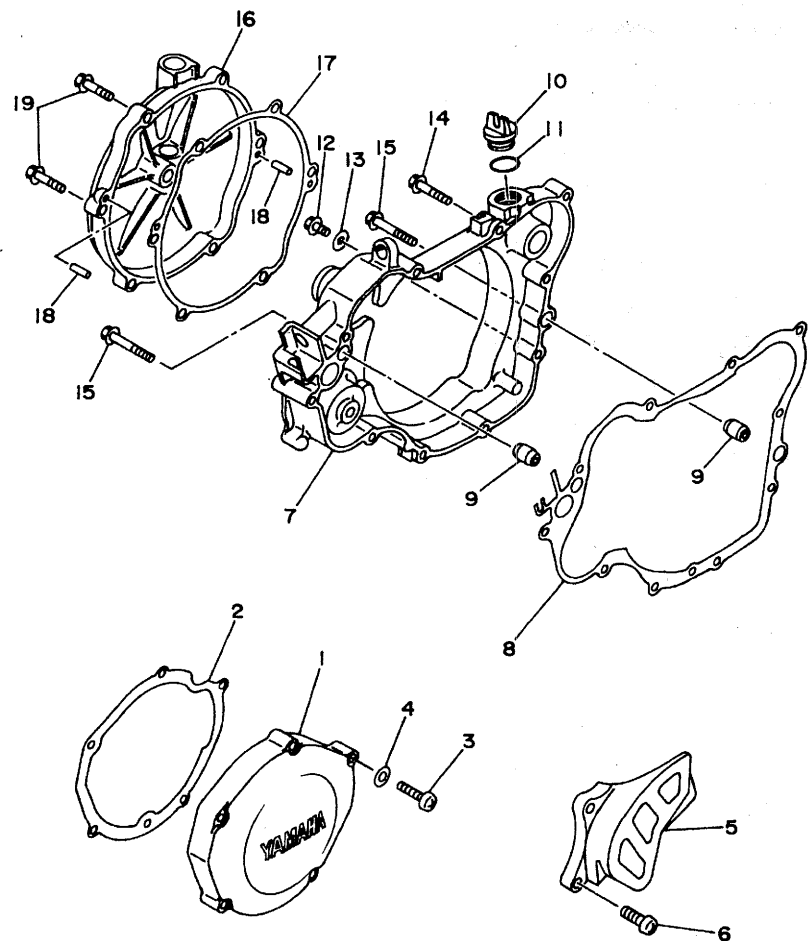


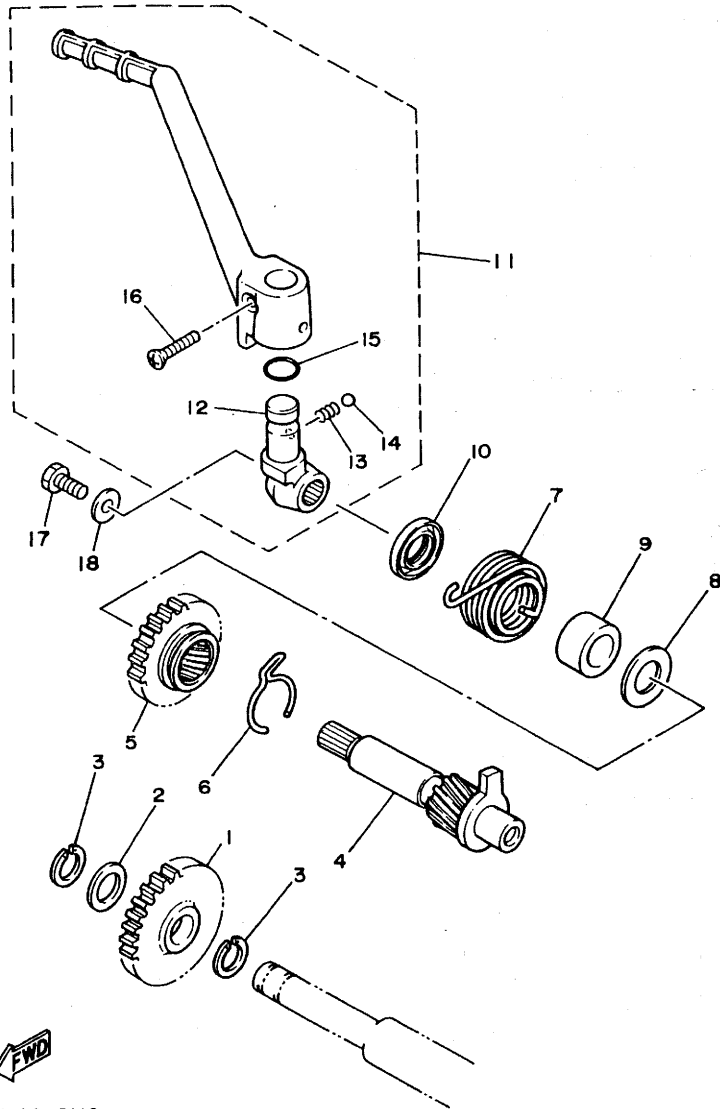
FIG. 10 CRANKCASE COVER 1

REF. NO.	PART NO.	DESCRIPTION	Q'TY	REMARKS
1	4JY-15411-00	COVER, CRANKCASE 1	1	
2	4JY-15451-00	GASKET, CRANKCASE COVER 1	1	
3	98517-06030	SCREW, PAN HEAD	5	
4	92907-06600	WASHER, PLATE	5	
5	4EX-15421-00	COVER, CRANKCASE 2	1	
6	98507-06016	SCREW, PAN HEAD	2	
7	4JY-15431-00	COVER, CRANKCASE 3	1	
8	4JY-15462-00	GASKET, CRANKCASE COVER 3	1	
9	99530-10014	PIN, DOWEL	2	
10	1RG-15363-00	PLUG, OIL	1	
11	93210-19123	O-RING	1	
12	95027-06010	BOLT, FLANGE	1	
13	90430-06014	GASKET	1	
14	95027-06030	BOLT, FLANGE	6	
15	95027-06040	BOLT, FLANGE	2	
16	4JY-15415-00	COVER, GENERATOR	1	
17	4JY-15463-00	GASKET, CARBURETOR COVER 2	1	
18	93604-10011	PIN, DOWEL	2	
19	95027-06025	BOLT, FLANGE	6	



4JY1100-4100

FIG. 11 STARTER



REF. NO.	PART NO.	DESCRIPTION	Q'TY	REMARKS
1	1LX-15651-00	GEAR, KICK IDLE	1	
2	90201-152H7	WASHER, PLATE	1	
3	93440-15012	CIRCLIP	2	
4	1LX-15660-02	KICK AXLE ASSY	1	
5	1LX-15641-00	GEAR, KICK	1	
6	90468-26048	CLIP	1	
7	90508-26450	SPRING, TORSION	1	
8	90201-171G4	WASHER, PLATE	1	
9	90560-17279	SPACER	1	
10	93102-17263	OIL SEAL	1	
11	4DB-15620-03	KICK CRANK ASSY	1	
12	4DB-15621-03	.BOSS, KICK CRANK	1	
13	90501-12081	.SPRING, COMPRESSION	1	
14	93507-32031	.BALL	1	
15	93210-15171	.O-RING	1	
16	90152-06010	.SCREW, COUNTERSUNK	1	
17	97027-06012	BOLT	1	
18	90201-065F3	WASHER, PLATE	1	

4DB2100-2110

**B14**

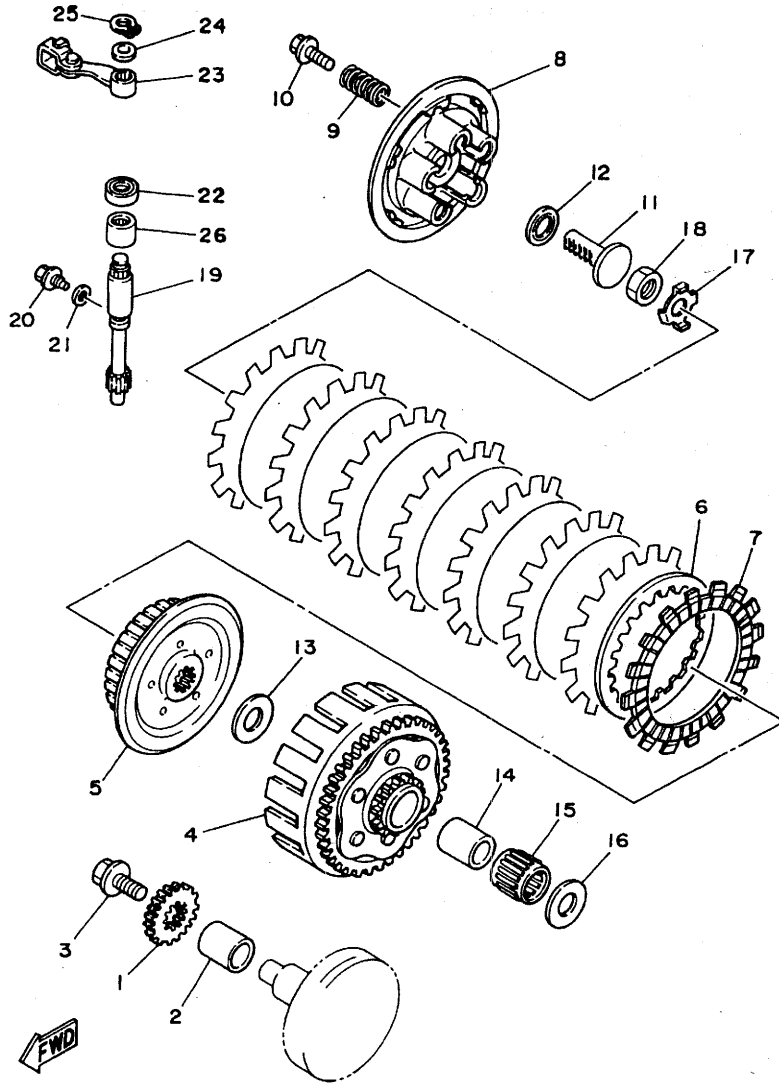
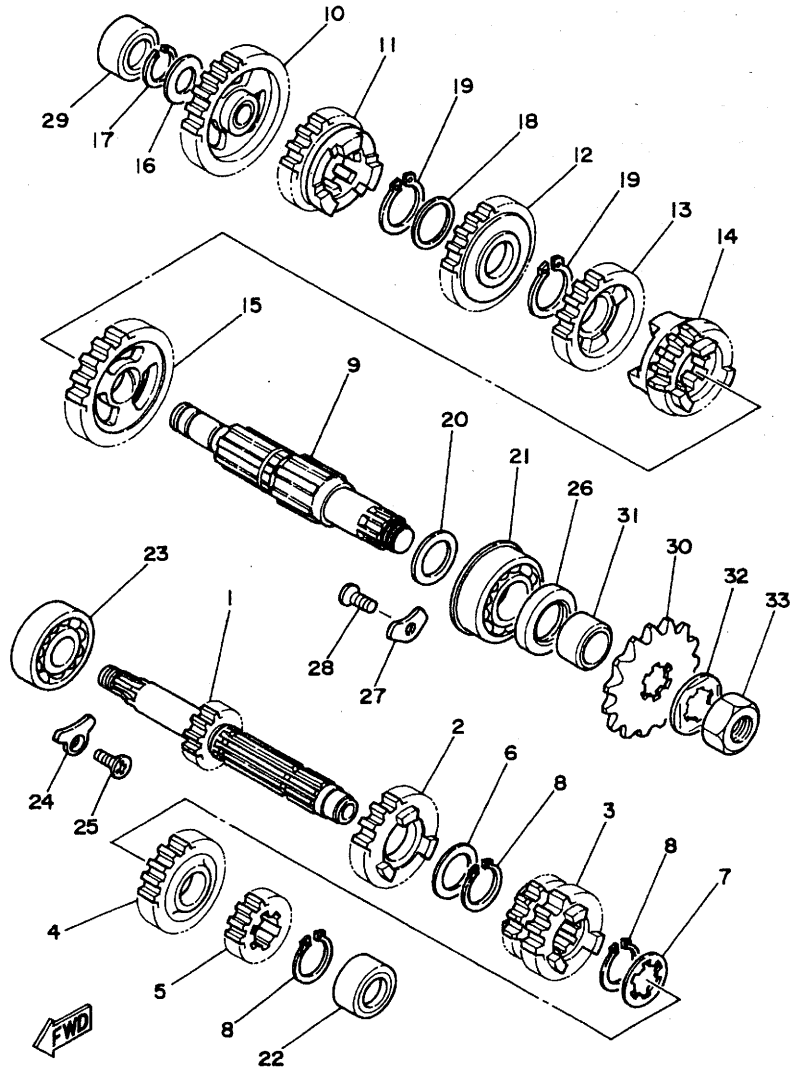


FIG. 12 CLUTCH

REF. NO.	PART NO.	DESCRIPTION	Q'TY	REMARKS
1	3XJ-16111-00	GEAR, PRIMARY DRIVE	1	
2	90387-202T9	COLLAR	1	
3	90105-10445	BOLT, WASHER BASED	1	
4	4JY-16150-01	PRIMARY DRIVEN GEAR COMP.	1	
5	4EX-16371-00	BOSS, CLUTCH	1	
6	3XJ-16324-00	PLATE, CLUTCH 1	7	
7	3XJ-16321-00	PLATE, FRICTION	8	
8	4EX-16351-00	PLATE, PRESSURE 1	1	
9	90501-23391	SPRING, COMPRESSION	5	
10	90159-06016	SCREW, WITH WASHER	5	
11	3SB-16356-00	ROD, PUSH 1	1	
12	93342-21013	BEARING, THRUST	1	
13	90201-204K8	WASHER, PLATE	1	
14	3XJ-16181-00	SPACER 1	1	
15	93310-225N0	BEARING, CYLINDRICAL	1	
16	3XJ-16164-00	PLATE, THRUST 2	1	
17	90215-16289	WASHER, LOCK	1	
18	90170-16326	NUT	1	
19	4EX-16382-00	AXLE, PUSH LEVER	1	
20	90109-06418	BOLT	1	
21	90430-06014	GASKET	1	
22	93102-12224	OIL SEAL	1	
23	3JD-16340-00	PUSH LEVER ASSY	1	
24	90201-10119	WASHER, PLATE	1	
25	99009-10400	CIRCLIP	1	
26	93315-11206	BEARING, CYLINDRICAL	1	

4JY1100-4120

FIG. 13 TRANSMISSION



3XJ1100-1130

REF. NO.	PART NO.	DESCRIPTION	Q'TY	REMARKS
1	3XJ-17411-00	AXLE, MAIN	1	
2	4EX-17151-00	GEAR, 5TH PINION	1	
3	4EX-17131-00	GEAR, 3RD PINION	1	
4	4EX-17161-00	GEAR, 6TH PINION	1	
5	3SR-17121-00	GEAR, 2ND PINION	1	
6	90201-22555	WASHER, PLATE	1	
7	90209-18135	WASHER	1	
8	93410-22039	CIRCLIP	3	
9	3XJ-17421-00	AXLE, DRIVE	1	
10	1LX-17211-01	GEAR, 1ST WHEEL	1	
11	4EX-17251-00	GEAR, 5TH WHEEL	1	
12	3SR-17231-00	GEAR, 3RD WHEEL	1	
13	4EX-17241-00	GEAR, 4TH WHEEL	1	
14	4EX-17261-00	GEAR, 6TH WHEEL	1	
15	3XJ-17221-00	GEAR, 2ND WHEEL	1	
16	90201-154E8	WASHER, PLATE (1.0T)	1	
17	93440-15012	CIRCLIP	1	
18	90209-18208	WASHER	1	
19	93410-22039	CIRCLIP	2	
20	90201-206K8	WASHER, PLATE	1	
21	93306-30411	BEARING (B6304)	1	
22	93311-41530	BEARING, CYLINDRICAL	1	
23	93306-20469	BEARING	1	
24	1LX-15383-00	PLATE, BEARING COVER	1	
25	90151-06037	SCREW, COUNTERSUNK	1	
26	93102-26042	OIL SEAL	1	
27	3XJ-15383-00	PLATE, BEARING COVER	2	
28	90151-06037	SCREW, COUNTERSUNK	2	

C2

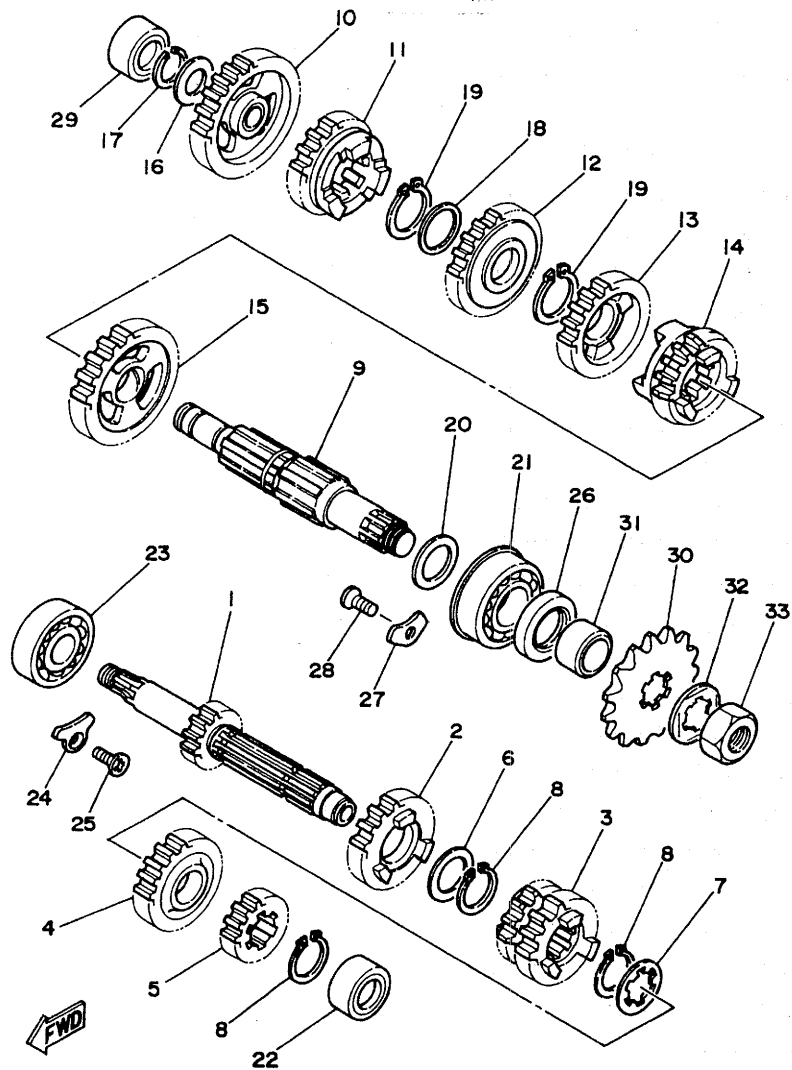
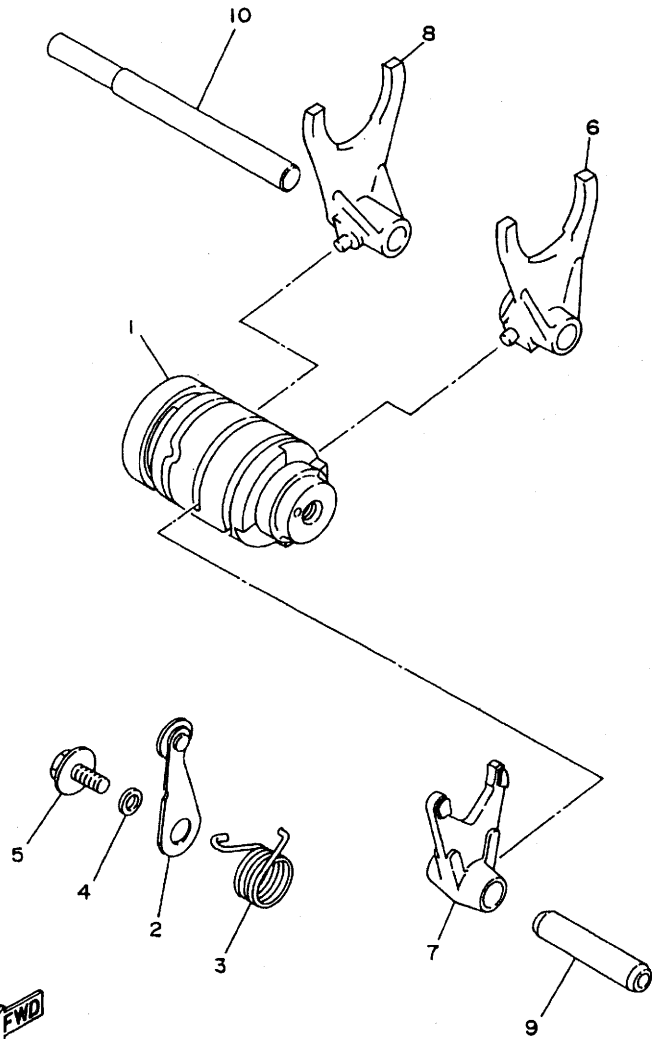


FIG. 13 TRANSMISSION

REF. NO.	PART NO.	DESCRIPTION	Q'TY	REMARKS
29	93311-31567	BEARING, CYLINDRICAL	1	
30	9383A-13031	SPROCKET, DRIVE 13T (2HG1746130)	1	STD
	9383A-12017	SPROCKET, DRIVE 12T (2HG1746120)	1	AP
	9383A-14054	SPROCKET, DRIVE 14T (2HG1746140)	1	AP
31	90387-202A0	COLLAR	1	
32	90215-20261	WASHER, LOCK	1	
33	90179-16226	NUT	1	

3XJ1100-1130

FIG. 14 SHIFT CAM. FORK

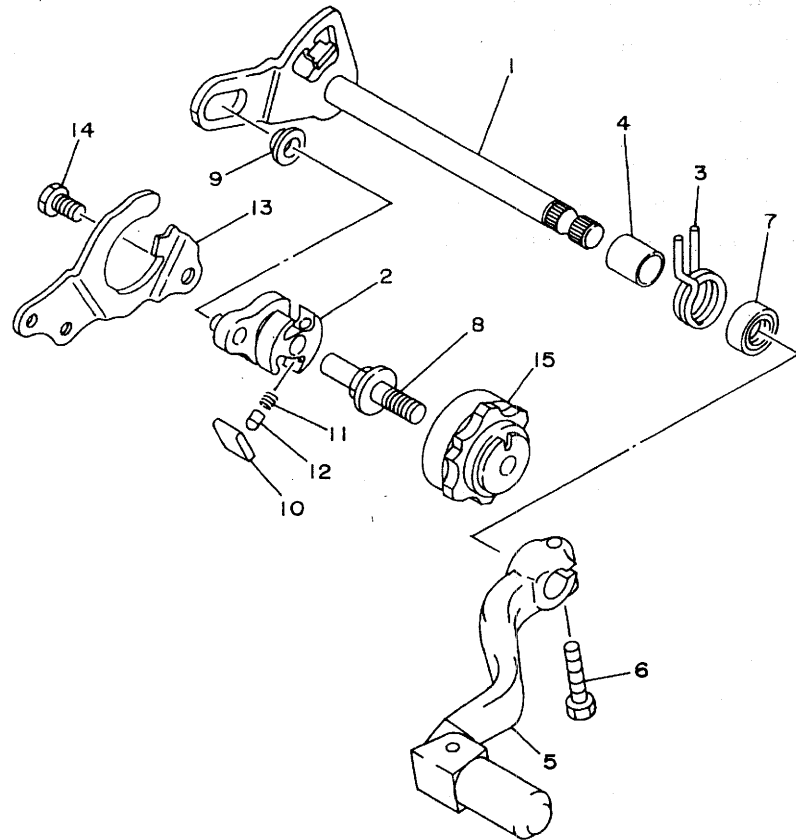


REF. NO.	PART NO.	DESCRIPTION	Q'TY	REMARKS
1	4JY-18540-00	SHIFT CAM ASSY	1	
2	4JY-18140-00	STOPPER LEVER ASSY	1	
3	90508-26691	SPRING, TORSION	1	
4	90387-063F7	COLLAR	1	
5	90159-06078	SCREW, WITH WASHER	1	
6	4SS-18511-00	FORK, SHIFT 1	1	
7	2VN-18512-01	FORK, SHIFT 2	1	
8	4SS-18513-00	FORK, SHIFT 3	1	
9	4EX-18531-00	BAR, SHIFT FORK GUIDE 1	1	
10	4EX-18535-00	BAR, SHIFT FORK GUIDE 2	1	

  
4SS1100-6140

**C4**

FIG. 15 SHIFT SHAFT



REF. NO.	PART NO.	DESCRIPTION	Q'TY	REMARKS
1	4SS-18101-00	SHIFT SHAFT ASSY	1	
2	3XJ-18122-00	LEVER, SHIFT 2	1	
3	90508-295A7	SPRING, TORSION	1	
4	90560-12280	SPACER	1	
5	4SS-18110-00	SHIFT PEDAL ASSY	1	
6	95027-06020	BOLT, FLANGE	1	
7	93109-12012	OIL SEAL	1	
8	3XJ-18173-00	PIN, SHIFT	1	
9	3XJ-18178-00	ROLLER, SHIFT LEVER	1	
10	3XJ-18182-00	PAWL, SHIFTER	2	
11	90501-052G5	SPRING, COMPRESSION	2	
12	3XJ-18184-00	PIN, PAWL	2	
13	4JY-18172-00	GUIDE, SHIFT	1	
14	90101-06664	BOLT	2	
15	4EW-18185-00	SEGMENT	1	



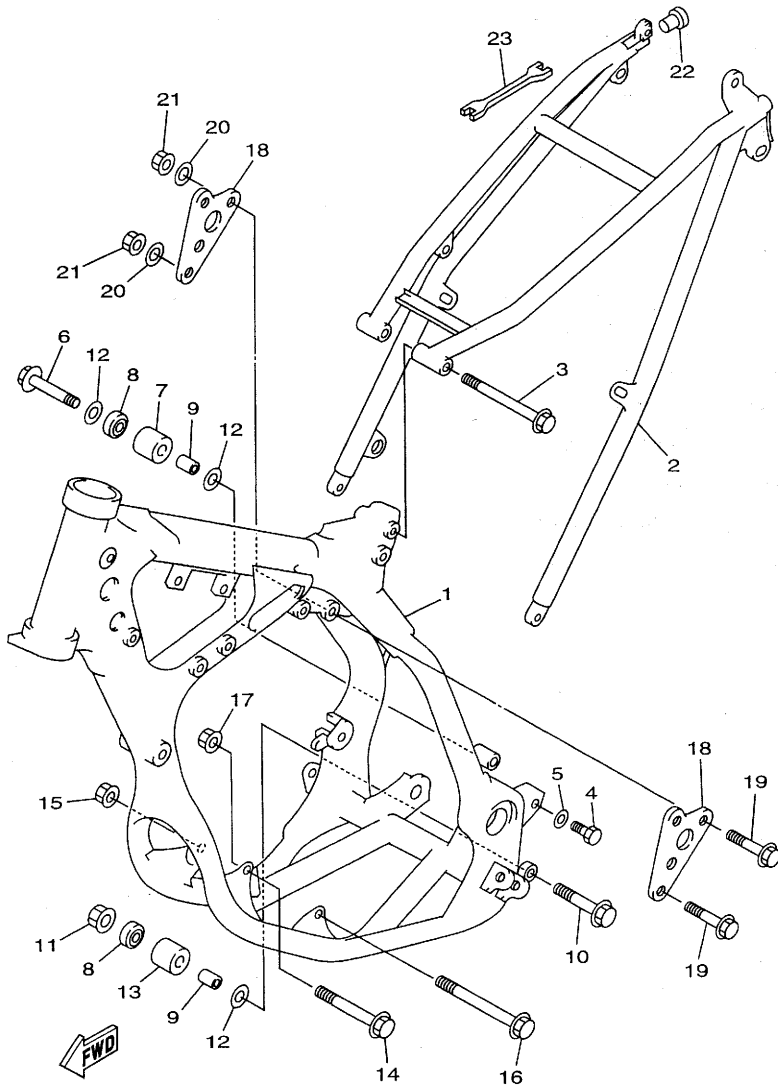
4SS1100-6150

C5

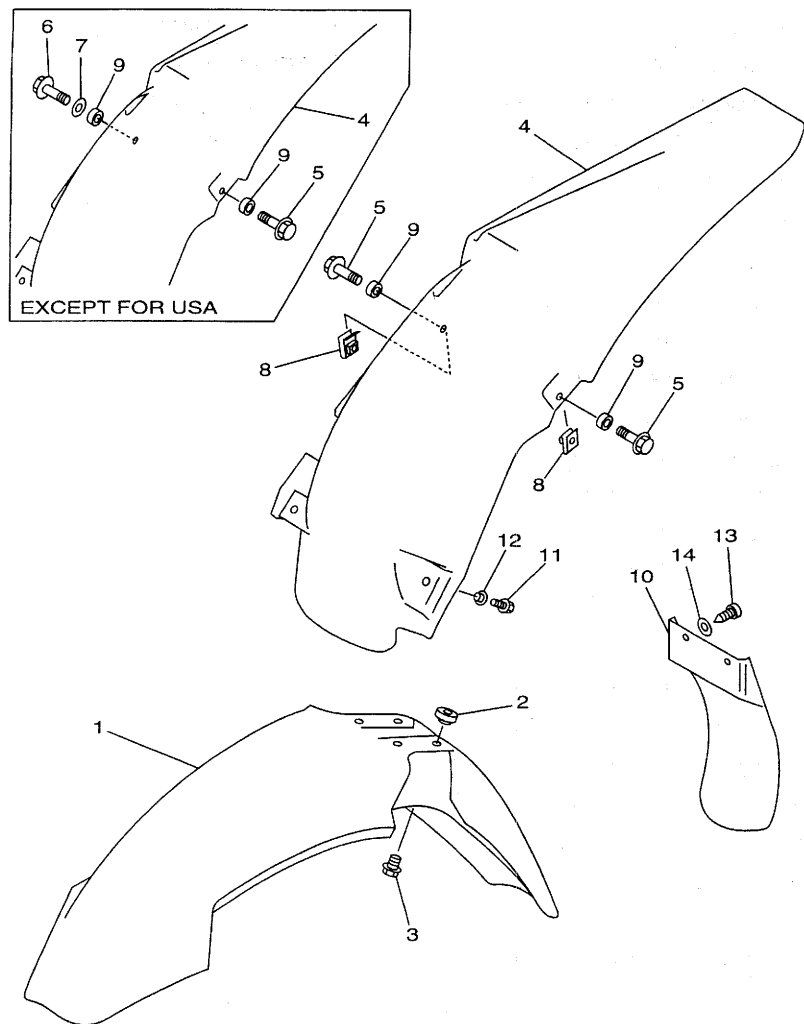


FIG. 16 FRAME

REF. NO.	PART NO.	DESCRIPTION	Q'TY	REMARKS
1	4SS-21101-00-UJ	FRONT FRAME COMP.	1	RADICAL WHITE
2	4SS-21190-00-UJ	REAR FRAME COMP.	1	UR RADICAL WHITE FOR U.S.A
	4SR-21190-00-UJ	REAR FRAME COMP.	1	UR RADICAL WHITE
3	90105-08099	BOLT, WASHER BASED	1	
4	90106-08051	BOLT	2	
5	90201-080E2	WASHER, PLATE	2	
6	95027-08040	BOLT, FLANGE	1	
7	4EW-22178-00	TENSIONER	1	
8	93300-60804	BEARING	2	
9	90387-086N4	COLLAR	2	
10	95027-08065	BOLT, FLANGE	1	
11	95707-08500	NUT, FLANGE	1	
12	90201-086P8	WASHER, PLATE	3	
13	3JD-22178-10	TENSIONER	1	
14	95817-08090	BOLT, FLANGE	1	
15	95617-08200	NUT, SELF-LOCKING	1	
16	90105-10733	BOLT, WASHER BASED	1	
17	95617-10200	NUT, SELF-LOCKING	1	
18	4SS-21425-00	BRACKET, REAR UPPER 1	2	
19	95817-08050	BOLT, FLANGE	3	
20	90201-08730	WASHER, PLATE	3	
21	95617-08200	NUT, SELF-LOCKING	3	
22	90338-16148	PLUG	2	
23	56A-28166-00	WRENCH, HEXAGON	1	



4SS1100-6160

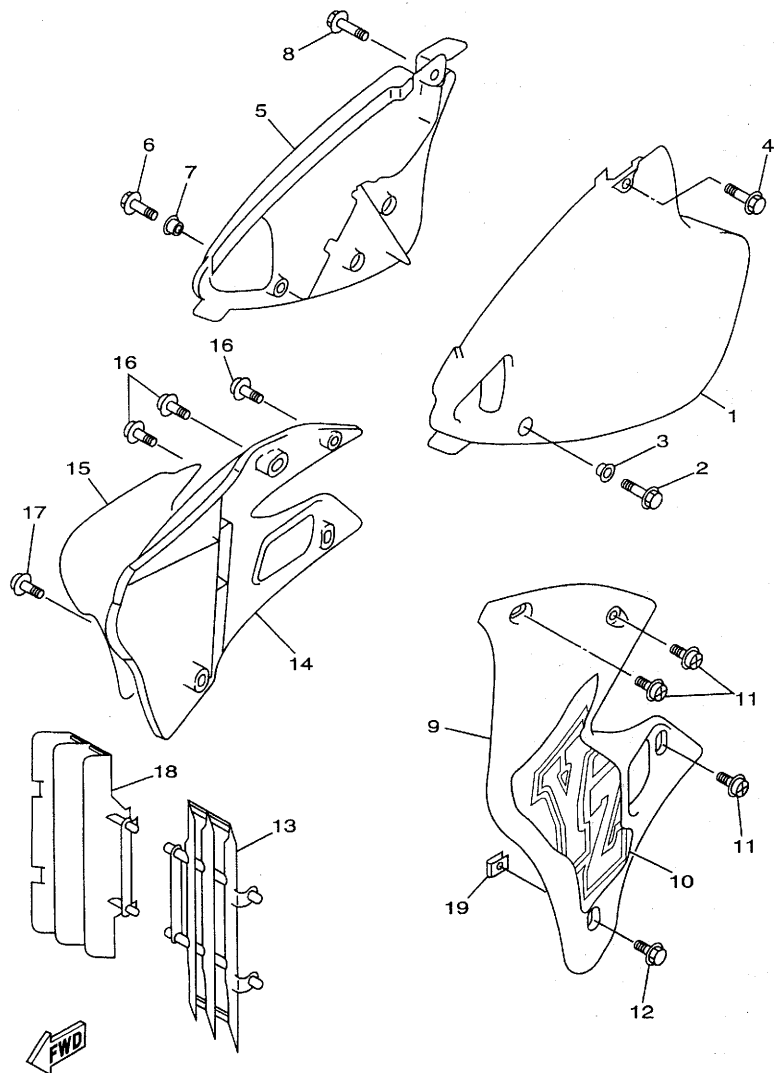


4SS1100-6170

FIG. 17 FENDER

REF. NO.	PART NO.	DESCRIPTION	Q'TY	REMARKS
1	4DA-21511-00	FENDER, FRONT	1	
2	3JD-21748-00	COLLAR	4	
3	90119-06096	BOLT, WITH WASHER	4	
4	4SS-21611-00	FENDER, REAR	1	
5	95027-06012	BOLT, FLANGE	2	FOR U.S.A
6	95027-06030	BOLT	1	EXCEPT FOR U.S.A
7	90201-06071	WASHER	1	EXCEPT FOR U.S.A
8	90183-06023	NUT, SPRING	2	
9	90387-0701A	COLLAR	2	
10	4ES-21642-00	GUARD, FLAP	1	
11	95027-06020	BOLT, FLANGE	2	
12	90387-0600F	COLLAR	2	
13	97707-60016	SCREW, TAPPING	2	
14	90201-065F3	WASHER, PLATE	2	

FIG. 18 SIDE COVER



REF. NO.	PART NO.	DESCRIPTION	Q'TY	REMARKS
1	4SS-21711-00	COVER, SIDE 1	1	
2	95817-06016	BOLT, FLANGE	1	
3	90387-0600F	COLLAR	1	
4	95817-06016	BOLT, FLANGE	1	
5	4SS-21721-00	COVER, SIDE 2	1	
6	95817-06016	BOLT, FLANGE	1	
7	90387-0600F	COLLAR	1	
8	95817-06016	BOLT, FLANGE	1	
9	4SS-21731-00	COVER, SIDE 3	1	
10	4SS-21783-01	EMBLEM 3	1	
11	90159-06182	SCREW, WITH WASHER	3	
12	90159-06078	SCREW, WITH WASHER	1	
13	4EW-2172A-10	PANEL 1	1	
14	4SS-21741-00	COVER, SIDE 4	1	
15	4SS-21784-01	EMBLEM 4	1	
16	90159-06182	SCREW, WITH WASHER	3	
17	90159-06078	SCREW, WITH WASHER	1	
18	4EW-2172A-10	PANEL 1	1	
19	90183-06069	NUT, SPRING	2	

4SS1100-6180

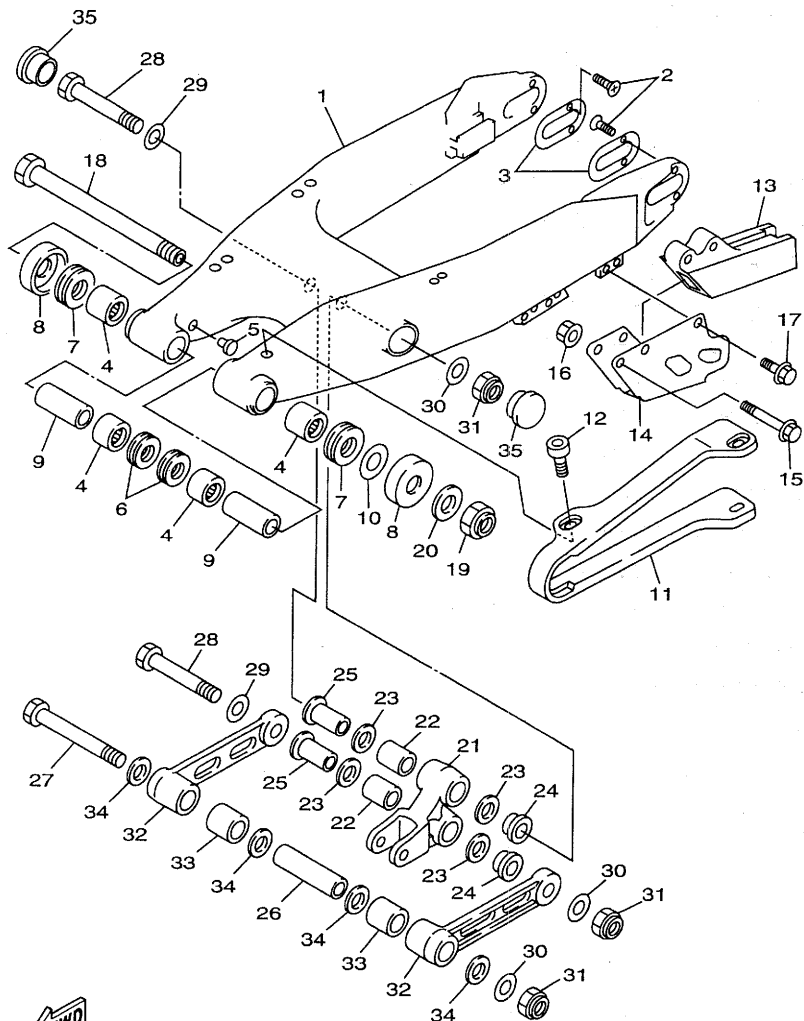


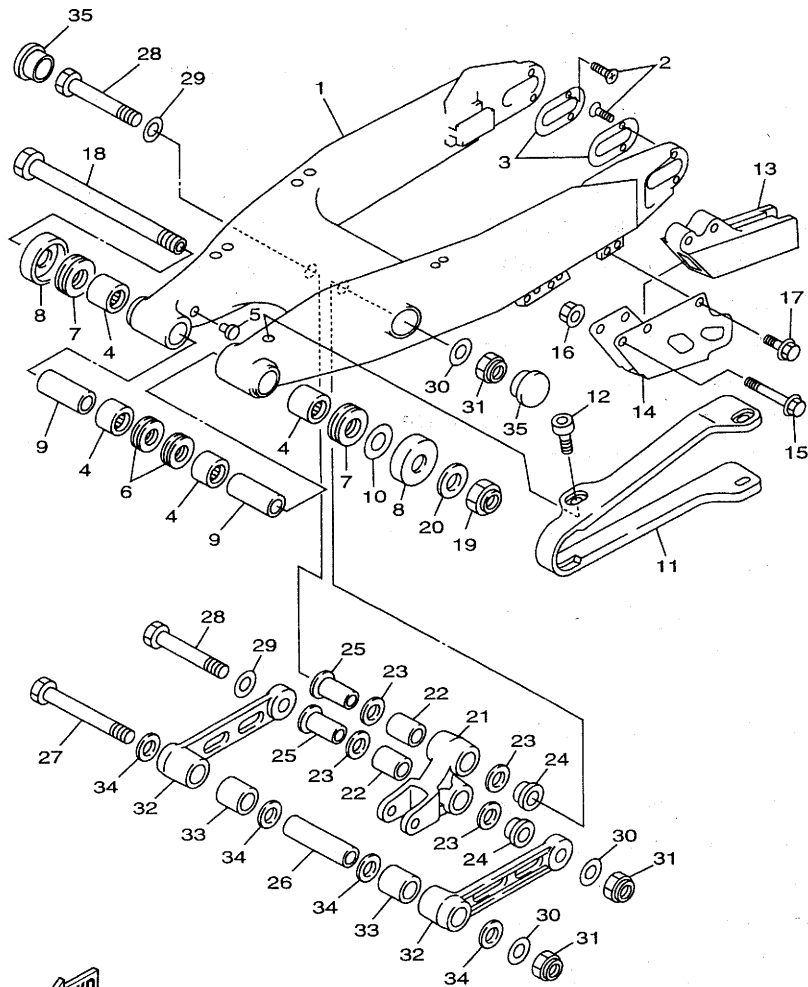
FIG. 19 REAR ARM

REF. NO.	PART NO.	DESCRIPTION	Q'TY	REMARKS
1	4SS-22110-01	REAR ARM COMP.	1	
2	90151-04048	SCREW, COUNTERSUNK	4	
3	4SS-22355-00	PATCH A	2	
4	93317-22262	BEARING, CYLINDRICAL	4	
5	90338-16148	PLUG	2	
6	93106-22019	OIL SEAL (DC 22-28-8)	2	
7	93342-22215	BEARING, THRUST	2	
8	4EW-22129-00	COVER, THRUST 2	2	
9	90380-16158	BUSH, SOLID	2	
10	156-22127-00	SHIM (0.3T)	1	
11	4EW-22151-01	SEAL, GUARD	1	
12	90110-05201	BOLT, HEXAGON SOCKET HEAD	4	
13	4EW-22199-01	SUPPORT, CHAIN	1	
14	4MX-22128-00	COVER, THRUST 1	1	
15	95027-06045	BOLT, FLANGE	2	
16	90179-06568	NUT	2	
17	95027-06010	BOLT, FLANGE	1	
18	1LX-22141-00	SHAFT, PIVOT	1	
19	90185-16127	NUT, SELF-LOCKING	1	
20	90201-164H4	WASHER, PLATE	1	
21	4SS-2217A-00	ARM, RELAY	1	
22	93315-22046	BEARING, CYLINDRICAL	2	
23	93109-20029	OIL SEAL	4	
24	90387-164N2	COLLAR	2	
25	90387-164N3	COLLAR	2	
26	90387-167Y9	COLLAR	1	
27	90109-147F2	BOLT	1	
28	90109-142F4	BOLT	2	

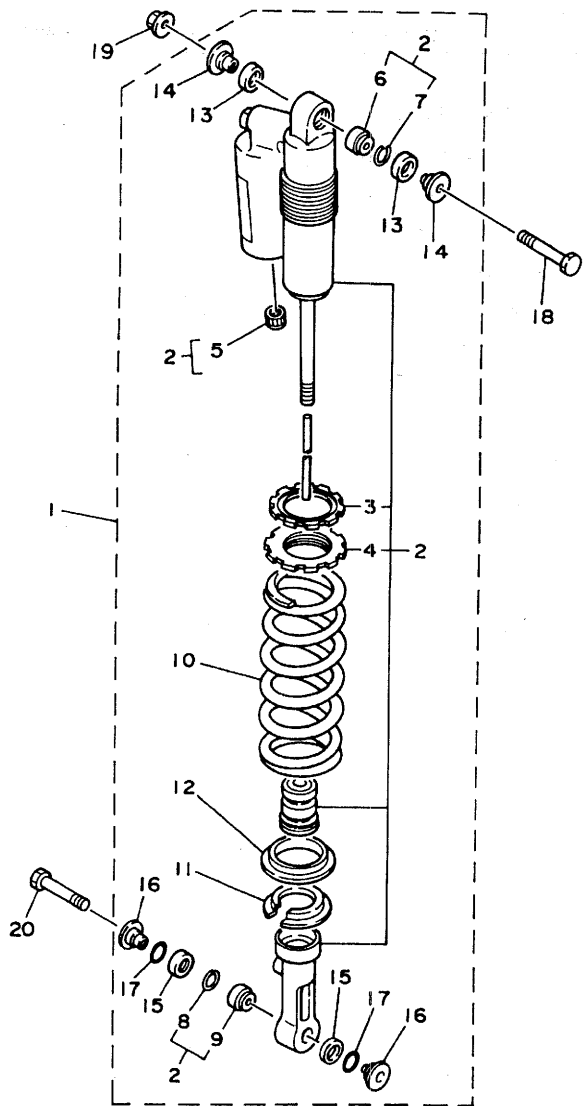
4SS1100-6190

FIG. 19 REAR ARM

REF. NO.	PART NO.	DESCRIPTION	Q'TY	REMARKS
29	90201-164H4	WASHER, PLATE	2	
30	90201-14740	WASHER, PLATE	3	
31	90185-14070	NUT, SELF-LOCKING	3	
32	4SS-2217F-00	ROD, CONNECTING 1	2	
33	93315-22046	BEARING, CYLINDRICAL	2	
34	93109-20029	OIL SEAL	2	
35	1HX-2135F-10	COVER	2	



4SS1100-6190

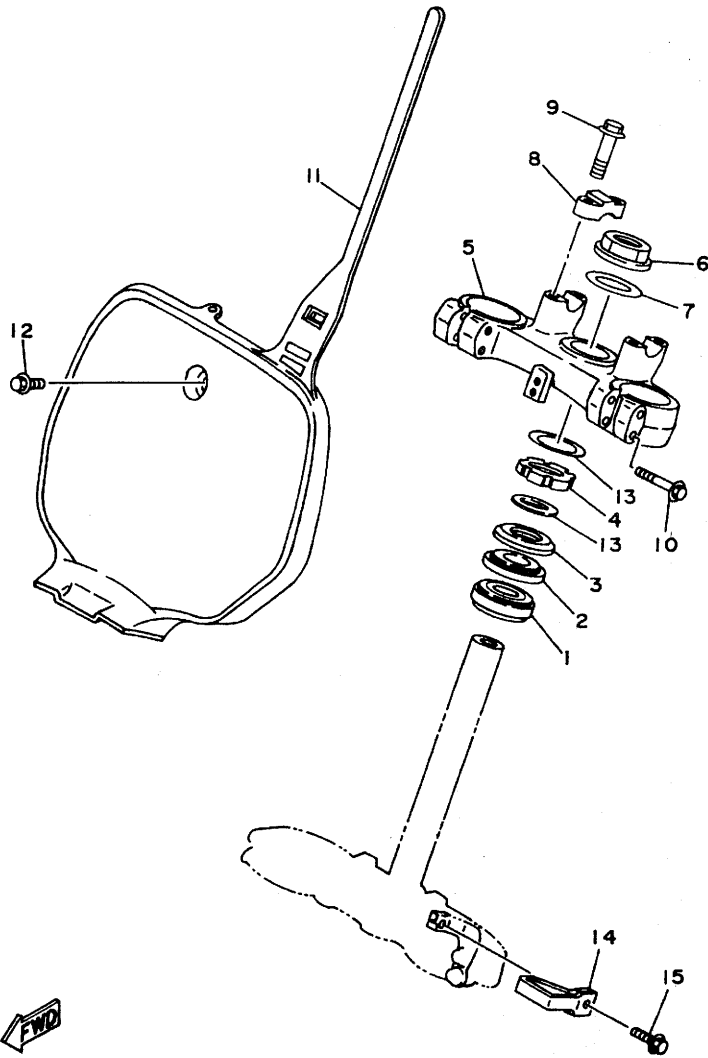


4JX1100-4200

FIG. 20 REAR SUSPENSION

REF. NO.	PART NO.	DESCRIPTION	Q'TY	REMARKS
1	4SS-22210-10	SHOCK ABSORBER ASSY, REAR	1	UR FOR U.S.A
	4SS-22210-00	SHOCK ABSORBER ASSY, REAR	1	UR FOR EUROPE,OCEANIA, S.AFRICA
	4SS-22210-20	SHOCK ABSORBER ASSY, REAR	1	UR FOR JAPAN
	4SS-22210-30	SHOCK ABSORBER ASSY, REAR	1	UR FOR CANADA
2	4SS-22201-10	.DAMPER SUB ASSY	1	UR FOR U.S.A
	4SS-22201-00	.DAMPER SUB ASSY	1	UR FOR EUROPE,OCEANIA, S.AFRICA
	4SS-22201-20	.DAMPER SUB ASSY	1	UR FOR JAPAN
	4SS-22201-30	.DAMPER SUB ASSY	1	UR FOR CANADA
3	3SP-22234-00	..GUIDE, SPRING 3	1	
4	3SP-22213-00	..SEAT, SPRING UPPER	1	
5	509-23184-L0	..CAP, AIR VALVE	1	
6	4MX-22216-00	..BUSH, REAR SHOCK ABSORBER	1	
7	43M-22274-00	..RING, STOP	1	
8	3Y6-23183-00	..CIRCLIP	1	
9	4JX-22226-00	..BUSH, SHOCK ABSORBER LOWER	1	
10	4JX-22212-20	..SPRING (K=4.6)	1	
11	3JD-22214-00	..GUIDE, SPRING 1	1	
12	3JD-22224-00	..GUIDE, SPRING 2	1	
13	3JD-22475-00	..SEAL, DUST	2	
14	3XJ-22253-00	..COLLAR, DISTANCE	2	
15	3JE-22475-00	..SEAL, DUST	2	
16	4EW-22253-00	..COLLAR, DISTANCE	2	
17	4EW-22474-00	..SEAL, RING	2	
18	3SP-22241-00	BOLT 1	1	
19	95617-10200	NUT, SELF-LOCKING	1	
20	90105-10614	BOLT, WASHER BASED	1	

FIG. 21 STEERING

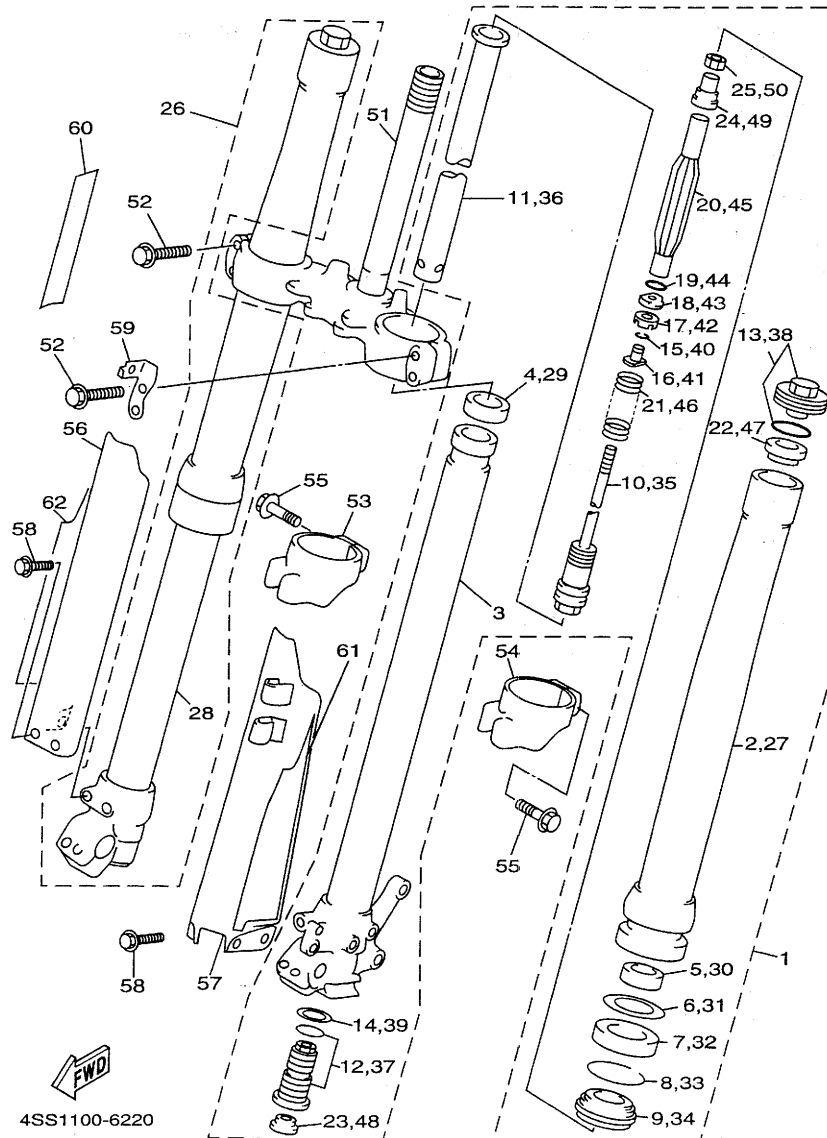


REF. NO.	PART NO.	DESCRIPTION	Q'TY	REMARKS
1	93332-00081	BEARING	1	
2	93332-00078	BEARING	1	
3	4EW-23416-00	COVER, BALL RACE 2	1	
4	90179-28650	NUT	1	
5	4SS-23435-00	CROWN, HANDLE	1	
6	90170-24373	NUT	1	
7	90201-247L2	WASHER, PLATE	1	
8	3SP-23441-00	HOLDER, HANDLE UPPER	2	
9	95027-08035	BOLT, FLANGE	4	
10	95027-08040	BOLT, FLANGE	4	
11	4DA-23485-01	PLATE, NUMBER	1	
12	90119-06185	BOLT, WITH WASHER	1	
13	90201-286K9	WASHER, PLATE	2	
14	4DA-23389-00	GUIDE, CABLE	1	
15	90105-05361	BOLT, WASHER BASED	1	

4JX1100-4210

C12

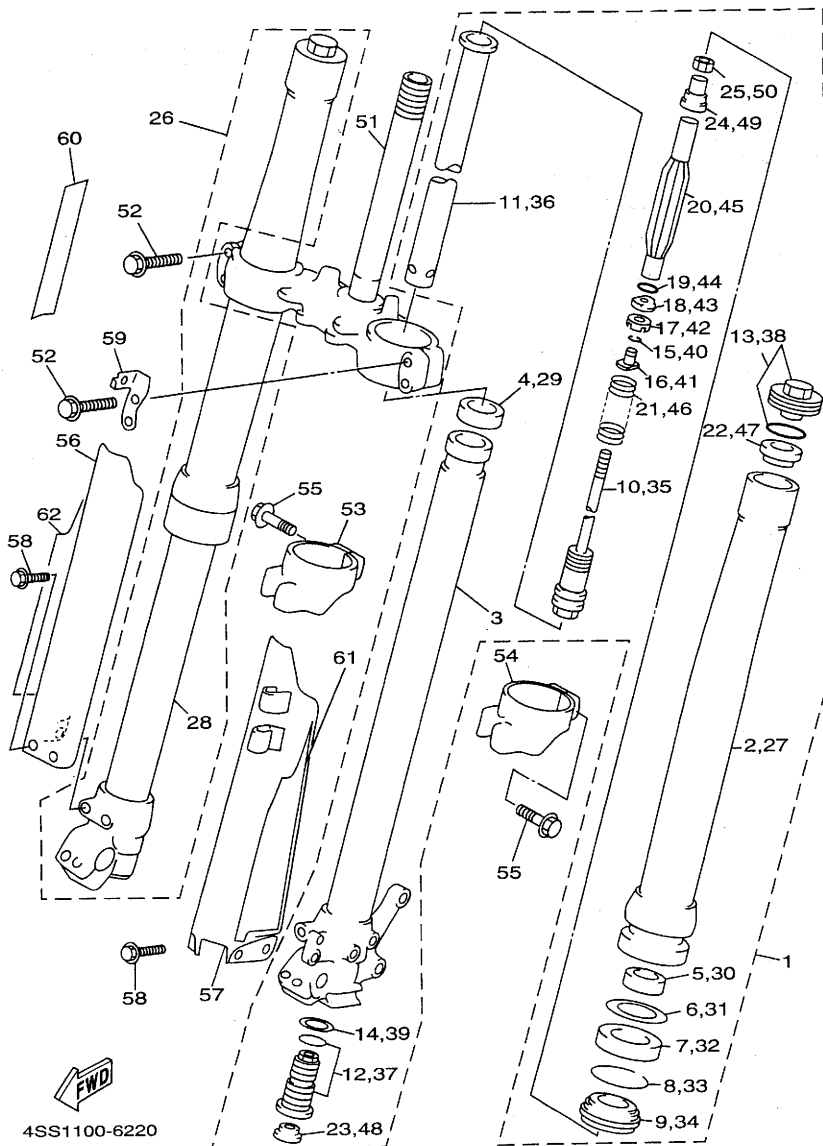
FIG. 22 FRONT FORK



REF. NO.	PART NO.	DESCRIPTION	Q'TY	REMARKS
1	4SS-23102-L0	FRONT FORK ASSY (L.H)	1	
2	4SS-23136-L0	.TUBE, OUTER (RIGHT)	1	
3	4SS-23120-L0	.INNER TUBE COMP.2	1	
4	4SS-23171-L0	.PISTON, FRONT FORK	1	
5	4SS-23125-L0	.METAL, SLIDE 1	1	
6	4SS-23146-L0	.WASHER, OIL SEAL	1	
7	4SS-23145-L0	.OIL SEAL	1	
8	4SS-23153-L0	.RING, SNAP	1	
9	4SS-23144-L0	.SEAL, DUST	1	
10	4SS-2314A-L0	.PISTON ROD ASSY	1	
11	4SS-23170-L0	.CYLINDER COMP., FRONT FORK	1	
12	4SS-2316A-L0	.VALVE COMP.	1	
13	4SS-23111-L0	.BOLT, CAP	1	
14	4SS-23158-L0	.GASKET	1	
15	3SP-23153-L0	.RING, SNAP	2	
16	3SP-23113-L0	.COLLAR	1	
17	3SP-23166-L0	.SPACER, OIL LOCK	1	
18	3SP-23393-L0	.NUT, SPECIAL	1	
19	3JD-23147-L0	.O-RING	1	
20	4SS-23142-L0	.SEAT, SPRING UPPER	1	
21	4SS-23141-L0	.SPRING, FRONT FORK (K=0.40)	1	
22	4SS-23143-L0	.SEAT, SPRING LOWER	1	
23	3JD-2312G-L0	.PLUG	1	
24	4SS-23363-L0	.COLLAR 1	1	
25	3SP-23357-L0	.NUT	1	
26	4SS-23103-L0	FRONT FORK ASSY (R.H)	1	
27	4SS-23136-L0	.TUBE, OUTER (RIGHT)	1	
28	4SS-23110-L0	.INNER TUBE COMP.1	1	



FIG. 22 FRONT FORK



REF. NO.	PART NO.	DESCRIPTION	QTY	REMARKS
29	4SS-23171-L0	.PISTON, FRONT FORK	1	
30	4SS-23125-L0	.METAL, SLIDE 1	1	
31	4SS-23146-L0	.WASHER, OIL SEAL	1	
32	4SS-23145-L0	.OIL SEAL	1	
33	4SS-23153-L0	.RING, SNAP	1	
34	4SS-23144-L0	.SEAL, DUST	1	
35	4SS-2314A-L0	.PISTON ROD ASSY	1	
36	4SS-23170-L0	.CYLINDER COMP., FRONT FORK	1	
37	4SS-2316A-L0	.VALVE COMP.	1	
38	4SS-23111-L0	.BOLT, CAP	1	
39	4SS-23158-L0	.GASKET	1	
40	3SP-23153-L0	.RING, SNAP	2	
41	3SP-23113-L0	.COLLAR	1	
42	3SP-23166-L0	.SPACER, OIL LOCK	1	
43	3SP-23393-L0	.NUT, SPECIAL	1	
44	3JD-23147-L0	.O-RING	1	
45	4SS-23142-L0	.SEAT, SPRING UPPER	1	
46	4SS-23141-L0	.SPRING, FRONT FORK (K=0.40)	1	
47	4SS-23143-L0	.SEAT, SPRING LOWER	1	
48	3JD-2312G-L0	.PLUG	1	
49	4SS-23363-L0	.COLLAR 1	1	
50	3SP-23357-L0	.NUT	1	
51	4SS-23340-L0	UNDER BRACKET COMP.	1	
52	95024-08040	BOLT, FLANGE	8	
53	4SS-2314G-L0	PROTECTOR GUIDE COMP., 2	1	
54	4SS-2314F-L0	PROTECTOR GUIDE COMP., 1	1	
55	4SS-23346-L0	BOLT 1	2	
56	4SS-2314J-00	PROTECTOR COMP., 2	1	

FIG. 22 FRONT FORK

REF. NO.	PART NO.	DESCRIPTION	Q'TY	REMARKS
57	4SS-2314H-00	PROTECTOR COMP., 1	1	
58	3SP-23356-L0	BOLT 2	6	
59	4EW-2331E-L0	GUIDE, CABLE	1	
60	99241-00160	EMBLEM, YAMAHA	2	
61	4SS-2313B-01	EMBLEM 1	1	
62	4SS-2313C-01	EMBLEM 2	1	

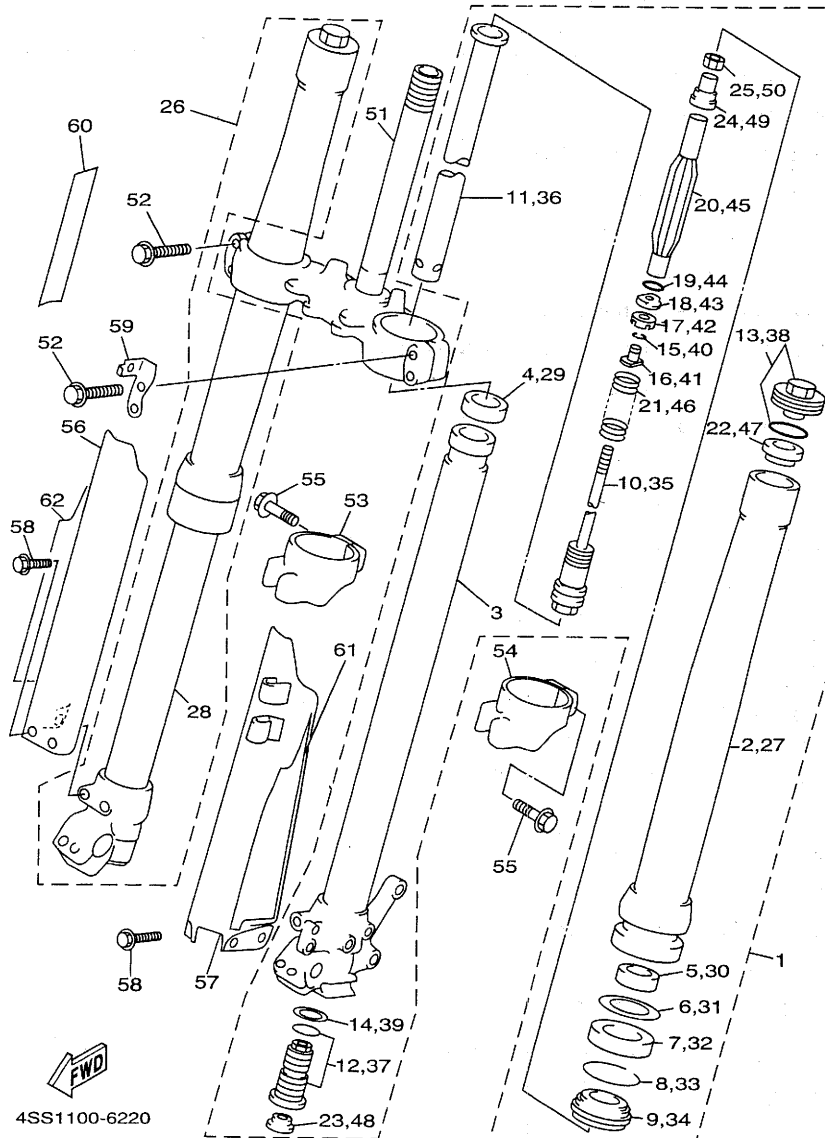
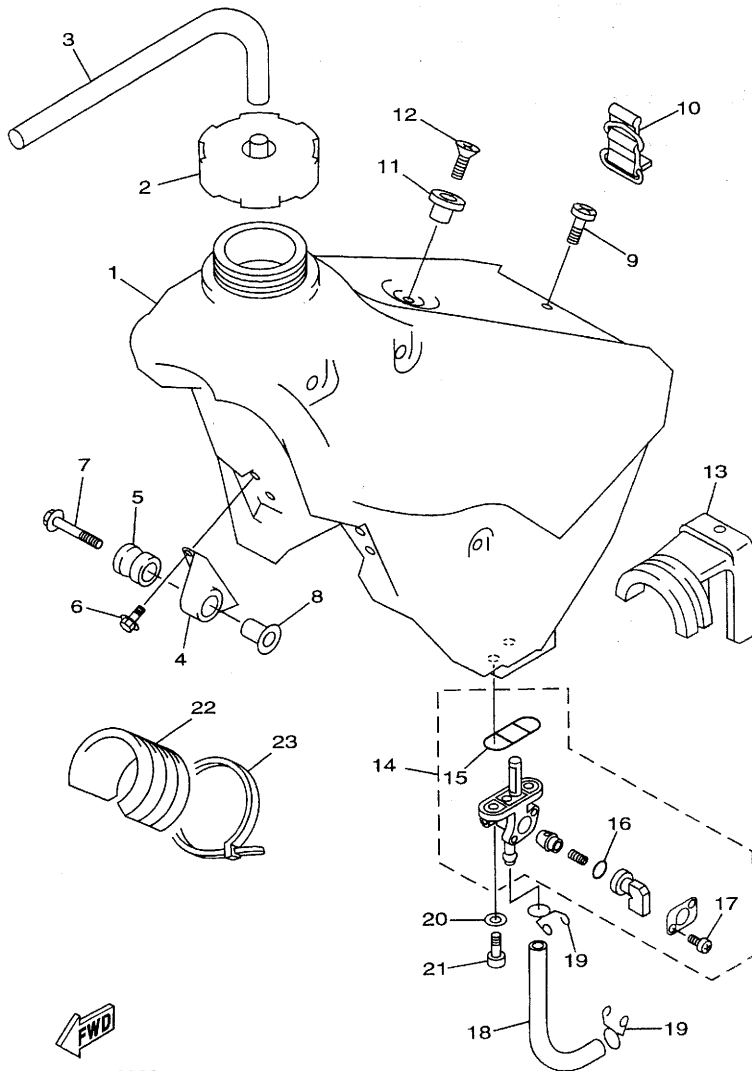


FIG. 23 FUEL TANK

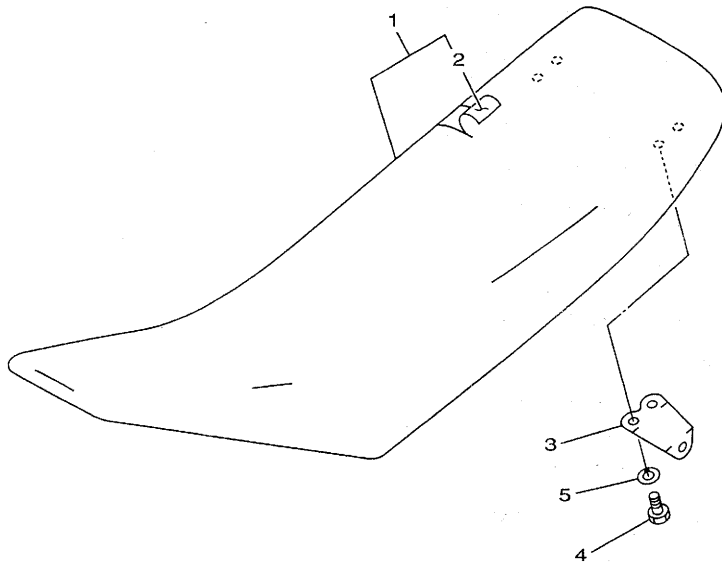
REF. NO.	PART NO.	DESCRIPTION	Q'TY	REMARKS
1	4SS-24110-00	FUEL TANK COMP.	1	
2	1UY-24610-00	CAP ASSY	1	
3	90445-09252	HOSE	1	
4	24X-24144-00	HOLDER, DAMPER	2	
5	90480-18549	GROMMET	2	
6	95027-06016	BOLT, FLANGE	4	
7	90119-06214	BOLT, WITH WASHER	2	
8	3JD-24186-00	WASHER, SPECIAL	2	
9	98907-06020	SCREW, BIND	1	
10	3SP-24173-00	BAND, TANK FITTING 1	1	
11	4EW-2412F-00	BRACKET, SEAT	1	
12	98707-06025	SCREW, FLAT HEAD	1	
13	4SS-24181-00	DAMPER, LOCATING 1	1	
14	3JD-24500-01	FUEL COCK ASSY 1	1	
15	4X8-24512-00	.O-RING	1	
16	3AJ-24534-00	.SEAL, COCK	1	
17	98580-03008	.SCREW, PAN HEAD	2	
18	90445-114J7	HOSE	1	
19	90467-10008	CLIP	2	
20	90202-05187	WASHER, PLATE	2	
21	90149-06011	SCREW	2	
22	4SS-24182-00	DAMPER, LOCATING 2	1	
23	90464-14117	CLAMP	1	



4SS1100-6230

FIG. 24 SEAT

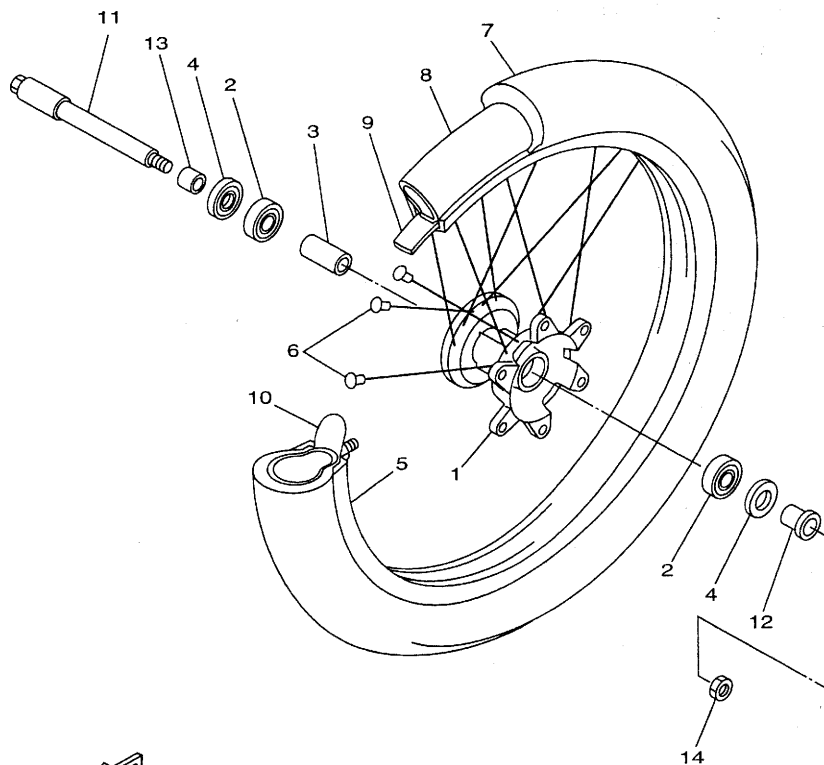
REF. NO.	PART NO.	DESCRIPTION	Q'TY	REMARKS
1	4SS-24770-00	SEMI-DOUBLE SEAT ASSY	1	
2	4SS-24731-00	.COVER, SEAT	1	
3	4SS-24728-00	.BRACKET, SEAT	2	
4	97027-06012	.BOLT	4	
5	92907-06100	.WASHER, SPRING	4	



4SS1100-6240

D3

FIG. 25 FRONT WHEEL



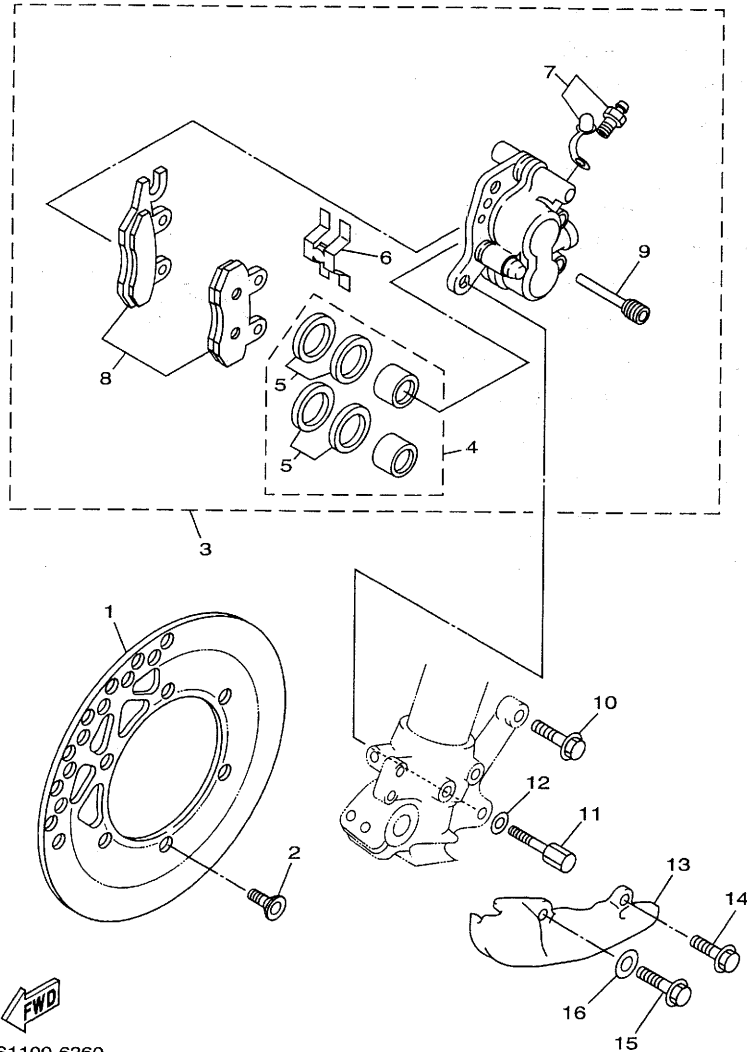
REF. NO.	PART NO.	DESCRIPTION	Q'TY	REMARKS
1	4SS-25111-00	HUB, FRONT	1	
2	93306-90403	BEARING	2	
3	90387-2007U	COLLAR	1	
4	93102-25360	OIL SEAL	2	
5	94416-21547	RIM (1.60-21)	1	
6	4DA-25104-00	SPOKE SET, FRONT	1	
7	94108-217X2	TIRE (80/100-21 K490)	1	UR DUNLOP
	94108-2102V	TIRE (80/100-21 51M D752F)	1	UR DUNLOP FOR EUROPE, CANADA
8	94227-21123	TUBE (2.75-21)	1	BRIDGESTONE
9	94307-21145	BAND, RIM (70-80/100-21)	1	DUNLOP
10	5X2-25394-00	SPACER, BEAD	1	
11	4SS-25181-00	AXLE, WHEEL	1	
12	90387-2007T	COLLAR	1	
13	90387-2007S	COLLAR	1	
14	90179-16672	NUT	1	



4SS1100-6250

**D4**

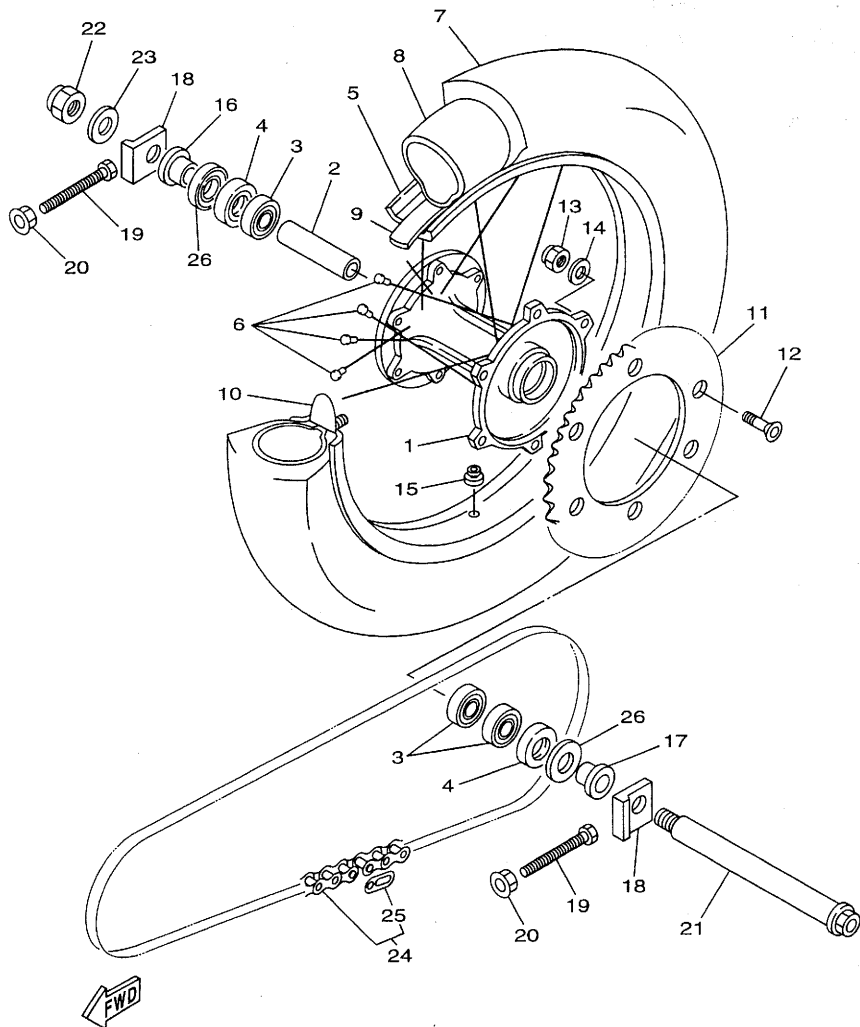
FIG. 26 FRONT BRAKE CALIPER



REF. NO.	PART NO.	DESCRIPTION	Q'TY	REMARKS
1	4JX-2582T-00	DISC, BRAKE	1	
2	90149-06272	SCREW	6	
3	4SS-2580T-00	CALIPER ASSY (LEFT)	1	
4	4EW-W0057-00	.PISTON ASSY, CALIPER	1	
5	3JD-W0047-00	..CALIPER SEAL KIT	1	
6	3SP-25919-01	.SUPPORT, PAD	1	
7	36Y-W0048-00	.BLEED SCREW KIT	1	
8	4SS-W0045-00	.BRAKE PAD KIT	1	
9	3GD-25933-00	.PIN, PAD	2	
10	90105-08659	BOLT, WASHER BASED	1	
11	90109-080G6	BOLT	1	
12	90201-090J9	WASHER, PLATE	1	
13	4SS-2314E-00	COVER, HOSE	1	
14	95817-06012	BOLT, FLANGE	1	
15	95027-08020	BOLT, FLANGE	1	
16	92907-08200	WASHER	1	

4SS1100-6260

FIG. 27 REAR WHEEL



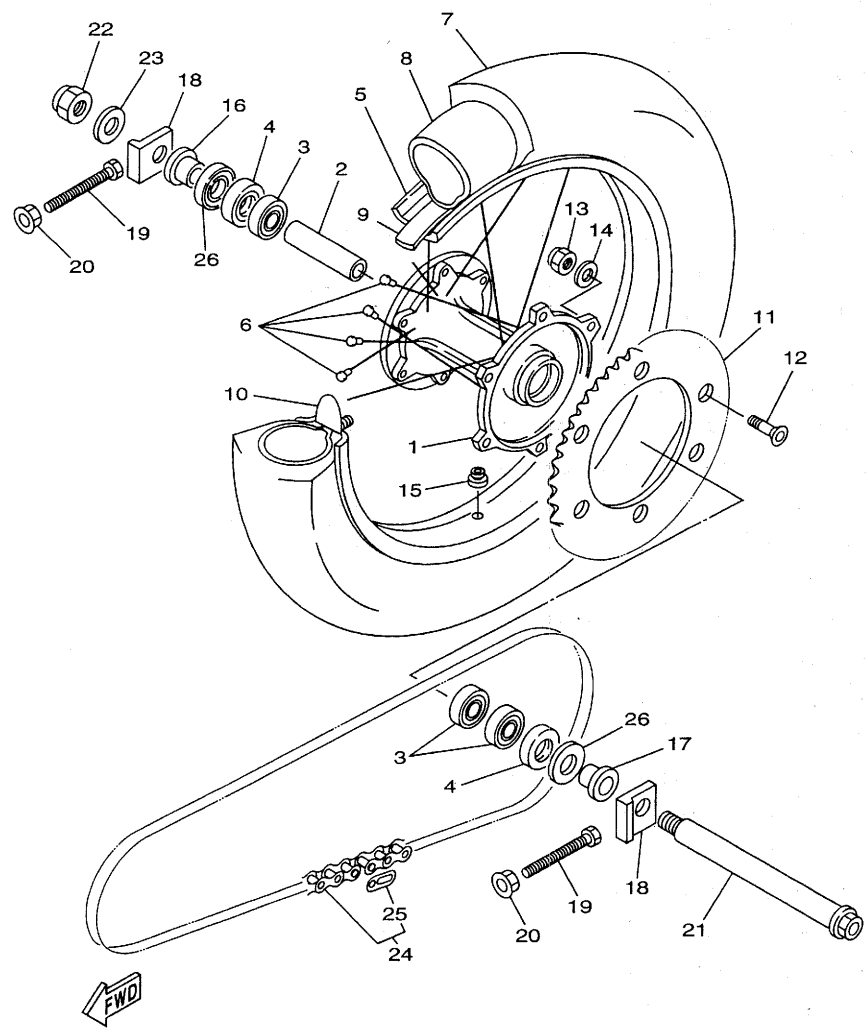
4SS1100-6270

REF. NO.	PART NO.	DESCRIPTION	Q'TY	REMARKS
1	4EW-25311-00	HUB, REAR	1	
2	90560-20278	SPACER	1	
3	93306-00418	BEARING	3	
4	93106-28023	OIL SEAL	2	
5	94418-19537	RIM (1.85-19)	1	
6	3JD-25304-00	SPOKE SET, REAR	1	
7	94110-1900X	TIRE (100/90-19 57M K695)	1	UR DUNLOP
	94110-1902X	TIRE (100/90-19 57M D752)	1	UR DUNLOP FOR EUROPE, CANADA
8	94210-19224	TUBE (100/90-19 TR4 BTL)	1	DUNLOP
9	94327-19111	BAND, RIM (2.75-19)	1	INOUE
10	2X3-25394-00	SPACER, BEAD	1	
11	4SS-25450-00	SPROCKET, DRIVEN (50T)	1	UR STD
	4SS-25447-00	SPROCKET, DRIVEN (47T)	1	AP
	4SS-25448-00	SPROCKET, DRIVEN (48T)	1	AP
	4SS-25449-00	SPROCKET, DRIVEN (49T)	1	AP
	4SS-25451-00	SPROCKET, DRIVEN (51T)	1	AP
	4SS-25452-00	SPROCKET, DRIVEN (52T)	1	AP
12	90109-081G1	BOLT	6	
13	95617-08100	NUT, U	6	
14	90201-086P8	WASHER, PLATE	6	
15	90480-10068	GROMMET	1	
16	90387-2000B	COLLAR	1	
17	90387-2000C	COLLAR	1	
18	3SP-25388-00	PULLER, CHAIN 1	2	
19	90101-08777	BOLT	2	
20	95707-08500	NUT, FLANGE	2	
21	3JD-25381-01	AXLE, WHEEL	1	
22	90185-18104	NUT, SELF-LOCKING	1	

D6

FIG. 27 REAR WHEEL

REF. NO.	PART NO.	DESCRIPTION	Q'TY	REMARKS
23	92907-18600	WASHER	1	
24	9Y581-65111	CHAIN (D.I.D.520DS DHA-112LL)	1	
25	94681-65001	JOINT, CHAIN	1	
26	4V4-25367-00	COVER, HUB DUST	2	

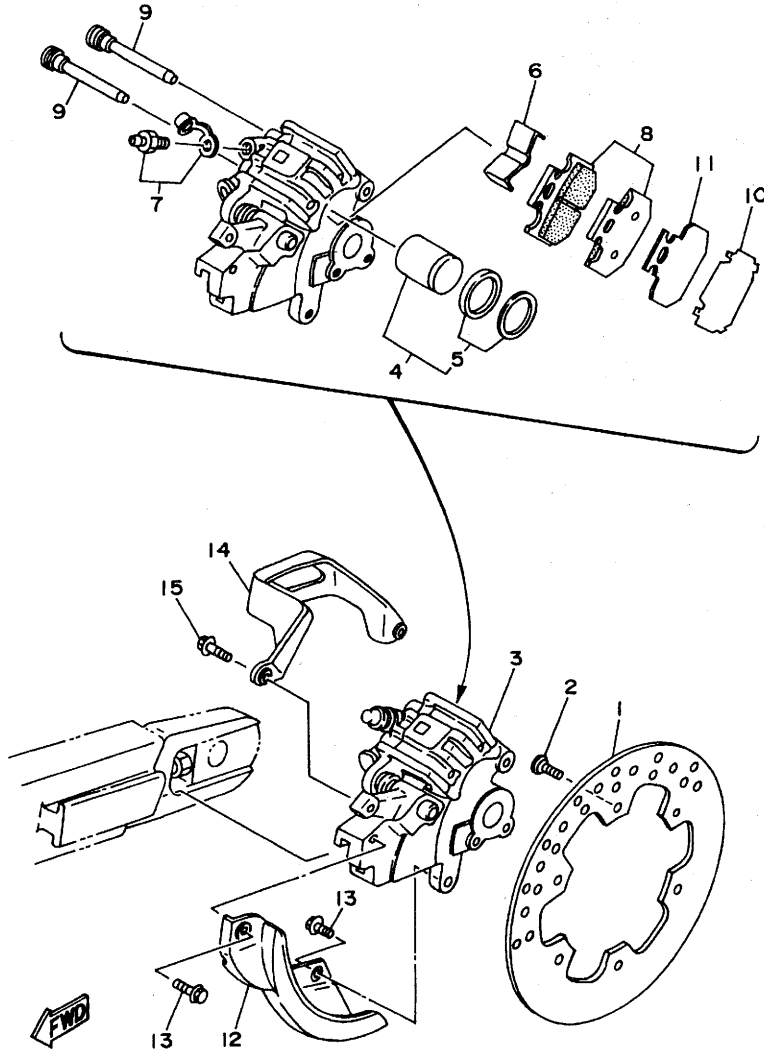


4SS1100-6270

**D7**



FIG. 28 REAR BRAKE CALIPER



REF. NO.	PART NO.	DESCRIPTION	Q'TY	REMARKS
1	4MX-2582W-00	DISC, REAR BRAKE 2	1	
2	90149-06272	SCREW	6	
3	4MX-2580W-00	CALIPER ASSY, REAR 2	1	
4	3SP-W0057-50	.PISTON ASSY, CALIPER	1	
5	3JD-W0047-50	..CALIPER SEAL KIT	1	
6	4GY-25919-50	.SUPPORT, PAD	1	
7	36Y-W0048-00	.BLEED SCREW KIT	1	
8	4GY-W0046-00	.BRAKE PAD KIT 2	1	
9	3SP-25924-51	.PIN, PAD	2	
10	4GY-25827-50	.SHIM, CALIPER	1	
11	4GY-22898-50	.INSULATOR, HEAT	1	
12	4MX-25718-00	PROTECTOR, DISK BRAKE	1	
13	95027-06012	BOLT, FLANGE	2	
14	4GY-27491-00	PROTECTOR	1	
15	95027-06016	BOLT, FLANGE	2	

4PE1100-5280

**D8**

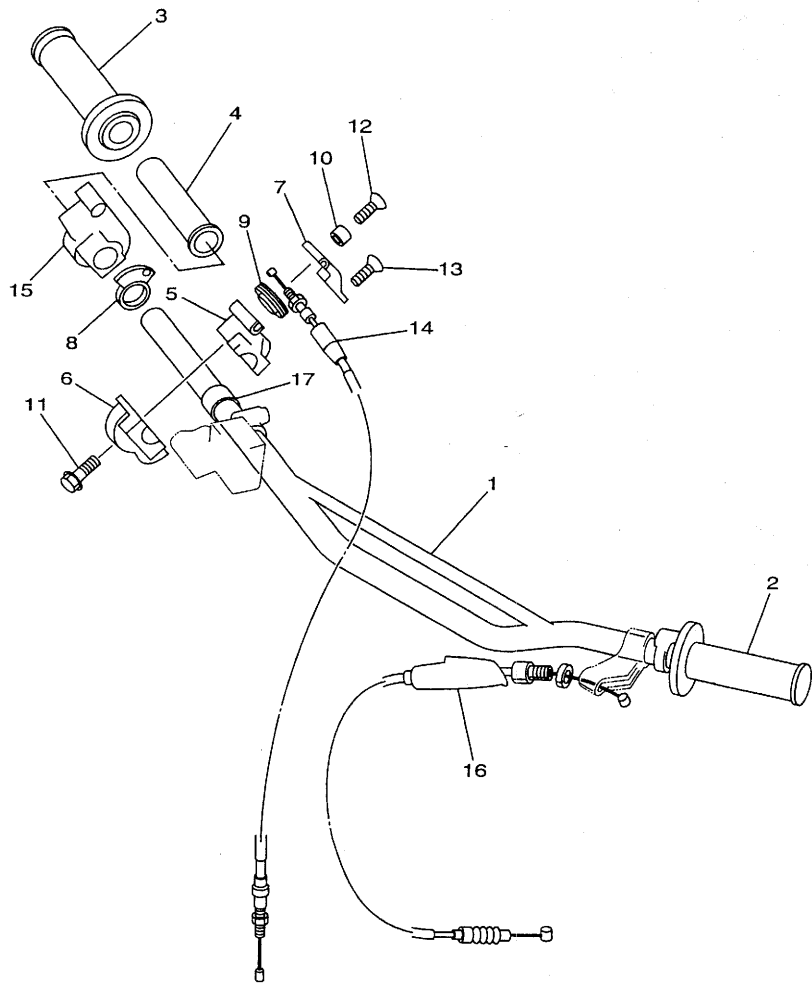


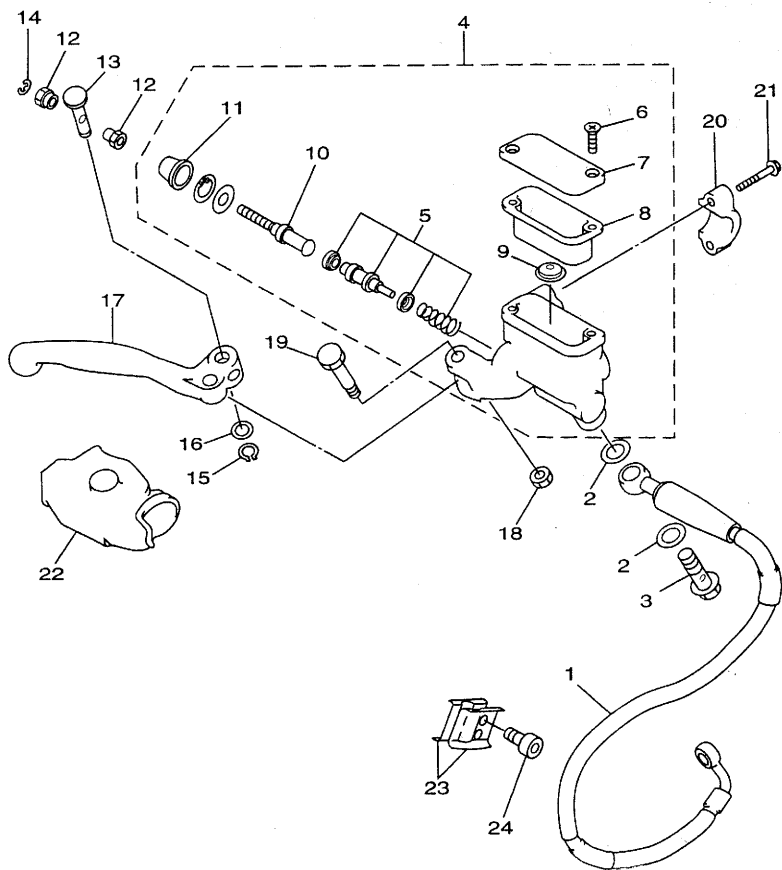
FIG. 29 STEERING HANDLE. CABLE

REF. NO.	PART NO.	DESCRIPTION	Q'TY	REMARKS
1	4JX-26111-00	HANDLEBAR	1	
2	4SS-26241-00	GRIP (LEFT)	1	
3	4SS-26242-00	GRIP (RIGHT)	1	
4	4SS-26243-00	TUBE, THROTTLE GUIDE	1	
5	4SS-26281-00	CAP, GRIP UPPER	1	
6	4SS-26282-01	CAP, GRIP LOWER	1	
7	4SS-2628H-00	CAP, WIRE	1	
8	4SS-2627A-00	ROTOR 2	1	
9	4SS-26273-00	ROTOR	1	
10	4SS-26259-00	COLLAR	1	
11	95027-06025	BOLT, FLANGE	2	
12	98707-04018	SCREW, FLAT HEAD	1	
13	98707-04010	SCREW, FLAT HEAD	1	
14	4SS-26311-01	CABLE, THROTTLE 1	1	
15	4SS-26287-01	COVER, CAP GRIP	1	
16	4JY-26335-00	CABLE, CLUTCH	1	
17	90387-227H7	COLLAR	1	

  
4SS1100-6290

**D9**

FIG. 30 FRONT MASTER CYLINDER



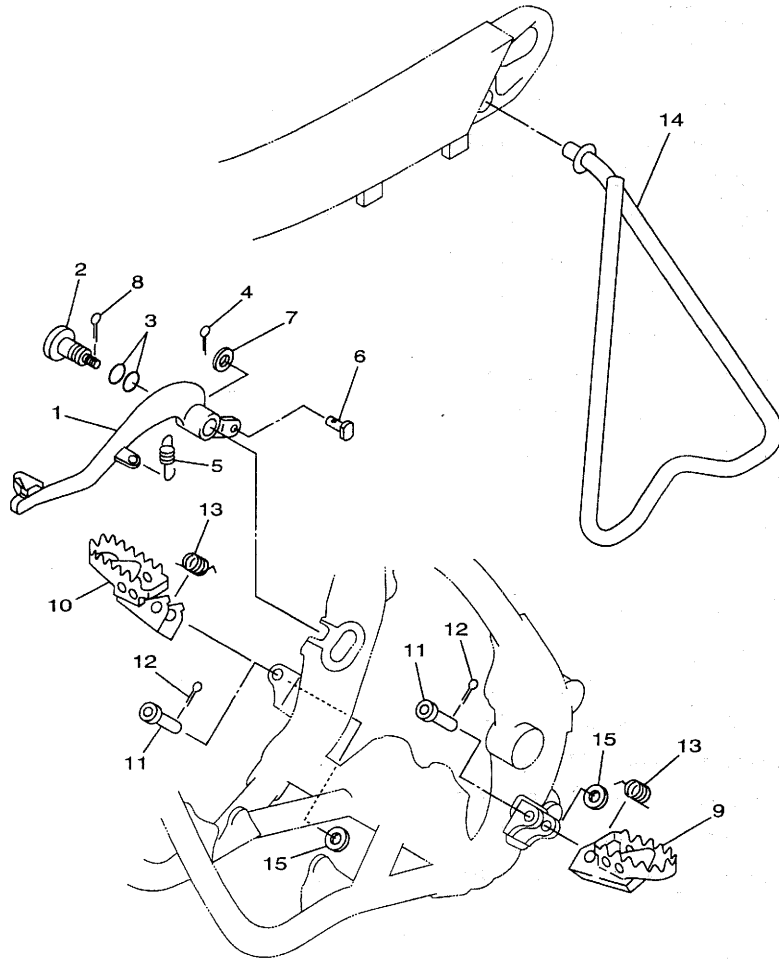
REF. NO.	PART NO.	DESCRIPTION	QTY	REMARKS
1	4SS-25872-00	HOSE, BRAKE 1	1	
2	90201-10118	WASHER, PLATE	4	
3	90401-10159	BOLT, UNION	2	
4	4SS-W2587-00	MASTER CYLINDER SUB ASSY	1	
5	4SS-W0041-00	.CYLINDER KIT, MASTER	1	
6	98707-04012	.SCREW, FLAT HEAD	2	
7	4SS-25852-00	.CAP, RESERVOIR	1	
8	4SS-25854-00	.DIAPHRAGM, RESERVOIR	1	
9	4SS-25889-00	.SEPARATOR ASSY	1	
10	4SS-25880-00	.PUSH ROD COMP.	1	
11	4SS-25868-00	.BOOT, MASTER CYLINDER	1	
12	4SS-2538E-00	NUT, ADJUSTING	2	
13	4SS-83913-00	COLLAR, LEVER 1	1	
14	3YX-25866-10	CIRCLIP	1	
15	4SS-25866-00	CIRCLIP	1	
16	4SS-2583G-00	WASHER	1	
17	4SS-83922-00	LEVER 2	1	
18	95617-06100	NUT, U	1	
19	4SS-2589F-00	BOLT, LEVER	1	
20	3YK-25867-00	BRACKET, MASTER CYLINDER	1	
21	4SS-25833-00	BOLT, FITTING	2	
22	4SS-26372-00	COVER, HANDLE LEVER 1	1	
23	90465-16258	CLAMP	2	
24	91317-06014	BOLT, SOCKET HEAD	2	



4SS1100-6300

D10

FIG. 31 STAND, FOOTREST



REF. NO.	PART NO.	DESCRIPTION	QTY	REMARKS
1	4SS-27200-00	PEDAL, BRAKE	1	
2	4SS-27217-00	BOLT	1	
3	93210-11073	O-RING	2	
4	91490-20025	PIN, COTTER	1	
5	90506-16500	SPRING, TENSION	1	
6	90240-08120	PIN, CLEVIS	1	
7	92990-08600	WASHER, PLATE	1	
8	90468-16191	CLIP	1	
9	4DA-27411-00	FOOTREST 1	1	
10	4DA-27421-00	FOOTREST 2	1	
11	90240-10117	PIN, CLEVIS	2	
12	91401-25020	PIN, COTTER	2	
13	90508-28777	SPRING, TORSION	2	
14	4ES-27311-00	STAND, SIDE	1	
15	90201-10119	WASHER, PLATE	2	

4SS1100-6310

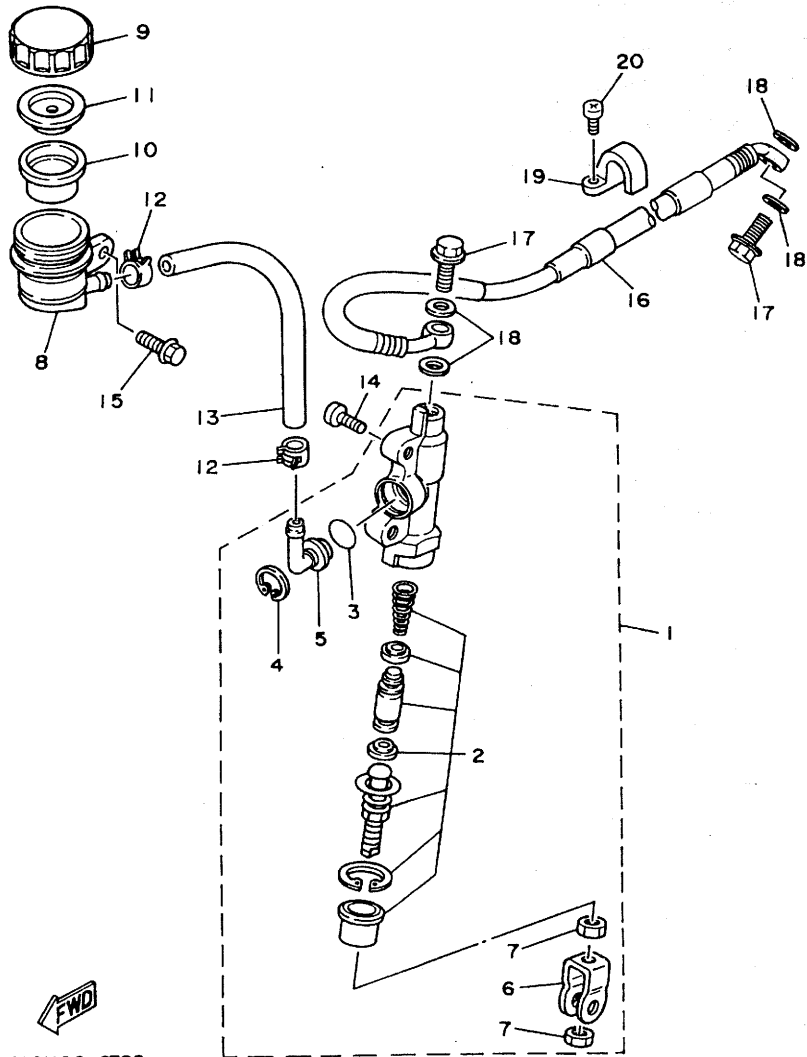


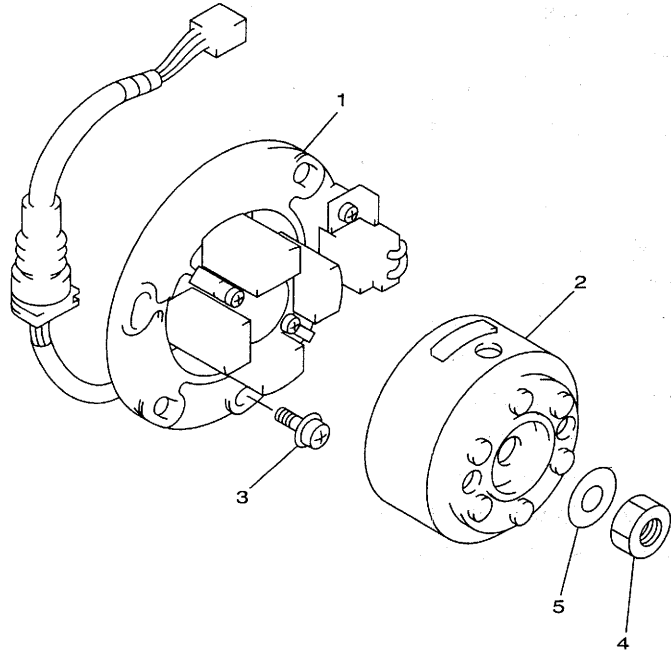
FIG. 32 REAR MASTER CYLINDER

REF. NO.	PART NO.	DESCRIPTION	Q'TY	REMARKS
1	3SP-2583V-00	RR. MASTER CYLINDER ASSY.	1	
2	4SS-W0042-50	.CYLINDER KIT, MASTER	1	
3	93210-15620	.O-RING	1	
4	2VN-25866-00	.CIRCLIP	1	
5	2VN-2582A-50	.JOINT	1	
6	3SP-27222-00	.JOINT	1	
7	95337-08600	.NUT	2	
8	4EW-25894-00	TANK, RESERVOIR	1	
9	3XP-25852-50	CAP, RESERVOIR	1	
10	2VN-25854-00	DIAPHRAGM, RESERVOIR	1	
11	2VN-25855-00	BUSH, DIAPHRAGM	1	
12	90467-11044	CLIP	2	
13	90445-137H9	HOSE	1	
14	92014-06016	BOLT, BUTTON HEAD	2	
15	95027-06012	BOLT, FLANGE	1	
16	4SS-25873-00	HOSE, BRAKE 2	1	
17	90401-10159	BOLT, UNION	2	
18	90201-10118	WASHER, PLATE	4	
19	2VM-25876-00	HOLDER, BRAKE HOSE 2	2	
20	97780-50110	SCREW, TAPPING	4	

FWD  
4SS1100-6320

FIG. 33 GENERATOR

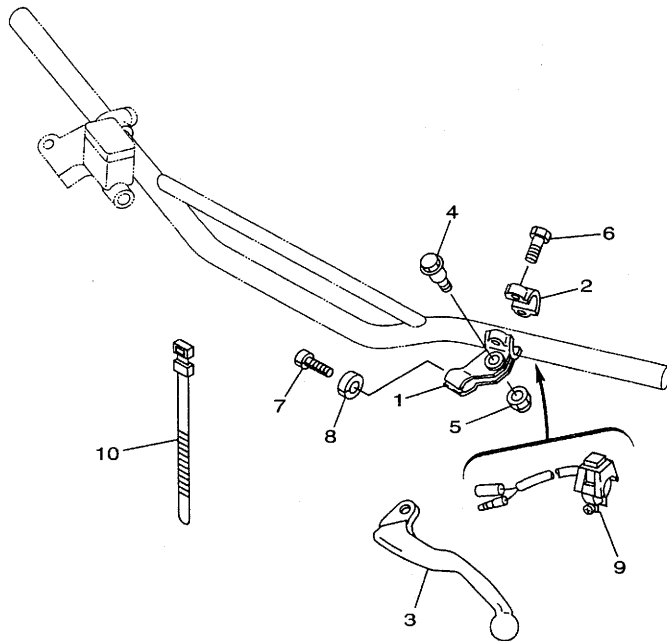
REF. NO.	PART NO.	DESCRIPTION	Q'TY	REMARKS
1	4SS-85560-00	BASE ASSY	1	
2	4SS-85550-00	ROTOR ASSY	1	
3	90149-06011	SCREW	3	
4	95317-10600	NUT	1	
5	90201-10774	WASHER, PLATE	1	



4SS1100-6330

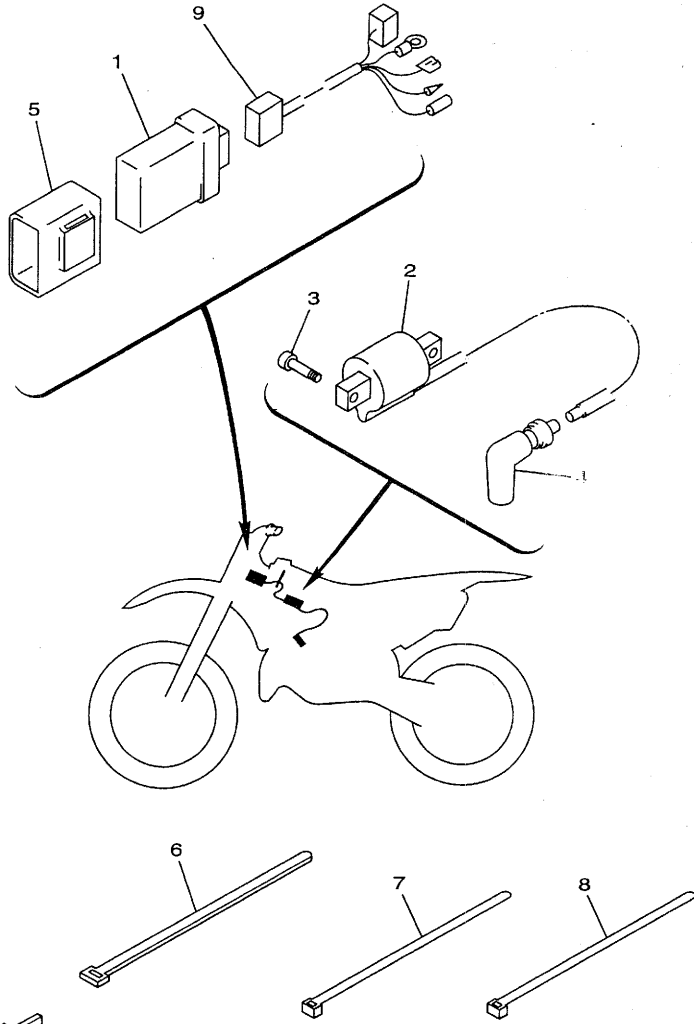
FIG. 34 HANDLE SWITCH. LEVER

REF. NO.	PART NO.	DESCRIPTION	Q'TY	REMARKS
1	38V-82911-00	HOLDER, LEVER 1	1	
2	38V-82913-00	HOLDER, LEVER LOWER 1	1	
3	4GY-83912-00	LEVER 1	1	
4	90109-06799	BOLT	1	
5	95617-06100	NUT, U	1	
6	97007-05016	BOLT	2	
7	90123-08090	BOLT	1	
8	90179-08401	NUT	1	
9	23X-83976-00	SWITCH, HANDLE 1	1	
10	437-83936-01	BAND, SWITCH CORD	2	



4SS1100-6340

FIG. 35 ELECTRICAL 1



REF. NO.	PART NO.	DESCRIPTION	Q'TY	REMARKS
1	4SS-85540-00	C.D.I. UNIT ASSY	1	
2	4SS-82310-00	IGNITION COIL ASSY	1	
3	91317-06016	BOLT, SOCKET HEAD	2	
4	4PE-82370-00	PLUG CAP ASSY	1	
5	4SS-85546-00	BAND	1	
6	25G-83936-01	BAND, SWITCH CORD	1	
7	12R-82591-00	BAND	1	
8	90464-14117	CLAMP	1	
9	4SS-82509-00	WIRE, SUB LEAD	1	

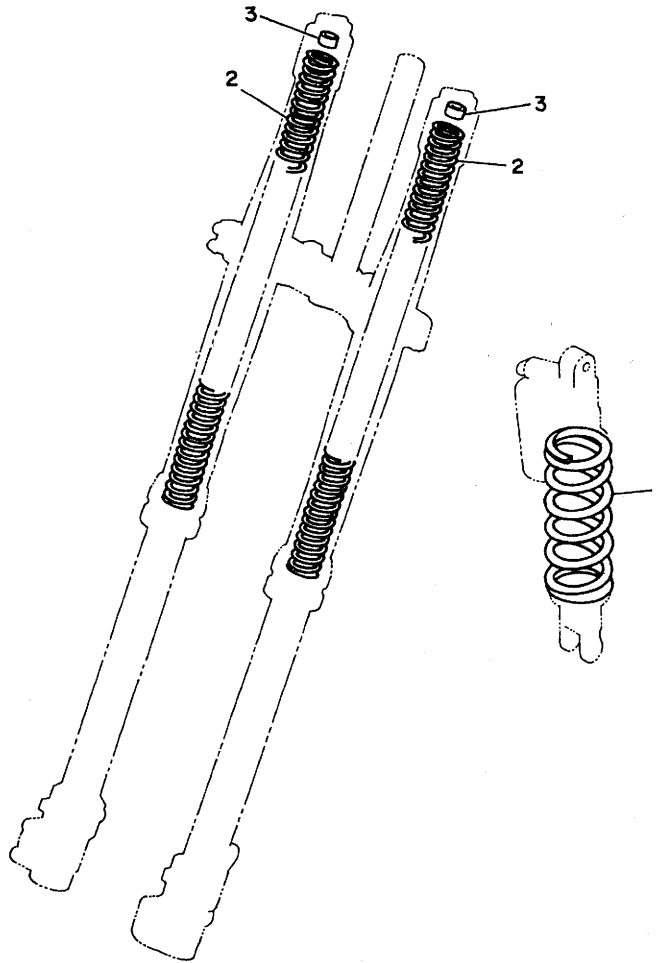


4SS1100-6350

**D15**



FIG. 36 ALTERNATE (CHASSIS)



REF. NO.	PART NO.	DESCRIPTION	Q'TY	REMARKS
1	4JX-22212-10	SPRING (K=4.4)	1	AP
	4JX-22212-20	SPRING (K=4.6)	1	AP
	4JX-22212-30	SPRING (K=4.8)	1	AP
	4JX-22212-40	SPRING (K=5.0)	1	AP
	4JX-22212-50	SPRING (K=5.2)	1	AP
	4JX-22212-60	SPRING (K=5.4)	1	AP
2	4SS-23141-10	SPRING, FRONT FORK (K=0.38)	2	AP
	4SS-23141-20	SPRING, FRONT FORK (K=0.39)	2	AP
	4SS-23141-30	SPRING, FRONT FORK (K=0.40)	2	AP
	4SS-23141-40	SPRING, FRONT FORK (K=0.41)	2	AP
	4SS-23141-50	SPRING, FRONT FORK (K=0.42)	2	AP
	4SS-23141-60	SPRING, FRONT FORK (K=0.43)	2	AP
	4SS-23141-70	SPRING, FRONT FORK (K=0.44)	2	AP
3	4SS-23364-L0	COLLAR 2	1	UN



3XJ1100-1360

E2

FIG. 37 OPTIONAL PARTS 1

REF. NO.	PART NO.	DESCRIPTION	QTY	REMARKS
1	4SS-11630-00	PISTON ASSY (STD)	1	
2	4JY-11631-02-B0	.PISTON (STD)	1	
3	4JY-11611-00	.RING, PISTON	1	
4	4PE-11633-00	.PIN, PISTON	1	
5	93450-17129	.CIRCLIP	2	
6	4SS-11650-00	CONNECTING ROD ASSY	1	
7	4PE-11651-01	.ROD, CONNECTING	1	
8	3JD-11681-01	.PIN, CRANK 1	1	
9	90209-22248	.WASHER	2	
10	93310-522P7	.BEARING, CYLINDRICAL	1	
11	93310-216L2	.BEARING, CYLINDRICAL	1	

# INDEX

NUMERICAL INDEX

PART NO.	GRID NO.	PART NO.	GRID NO.	PART NO.	GRID NO.	PART NO.	GRID NO.	PART NO.	GRID NO.	PART NO.	GRID NO.
4SS-W0041-00	D-10	4JY-11993-00	B-3	137-14143-74	B-10	3XJ-16164-00	B-15	4EW-2172A-10	C-8	4SS-23103-L0	C-13
4SS-W0042-50	D-12	4JY-11995-00	B-3	4PE-14147-00	B-10	3XJ-16181-00	B-15	4SS-21731-00	C-8	4SS-23110-L0	C-13
4SS-W0045-00	D-5	4SS-1240A-00	B-7	4PE-1416A-00	B-10	3XJ-16321-00	B-15	4SS-21741-00	C-8	4SS-23111-L0	C-13
4GY-W0046-00	D-8	4JY-12422-00	B-6	3JE-14171-00	B-9	3XJ-16324-00	B-15	3JD-21748-00	C-7	4SS-23111-L0	C-14
3JD-W0047-00	D-5	4JY-12428-00	B-6	4PE-14185-00	B-9	3JD-16340-00	B-15	4SS-21783-01	C-8	3SP-23113-L0	C-13
3JD-W0047-50	D-8	1LX-12450-00	B-6	353-14186-00	B-9	4EX-16351-00	B-15	4SS-21784-01	C-8	3SP-23113-L0	C-14
36Y-W0048-00	D-5	4SS-12459-00	B-6	4PE-14194-00	B-9	3SB-16356-00	B-15	4SS-22110-01	C-9	4SS-23120-L0	C-13
36Y-W0048-00	D-8	4SS-12461-00	B-7	2J2-14196-00	B-9	4EX-16371-00	B-15	156-22127-00	C-9	4SS-23125-L0	C-13
4EW-W0057-00	D-5	22W-12462-00	B-7	3X3-14197-00	B-9	4EX-16382-00	B-15	4MX-22128-00	C-9	4SS-23125-L0	C-14
3SP-W0057-50	D-8	4SS-12481-00	B-7	4PE-14197-00	B-10	3SR-17121-00	C-2	4EW-22129-00	C-9	3JD-23126-L0	C-13
4SS-11111-00	B-2	4SS-12482-00	B-7	4PE-14243-00	B-9	4EX-17131-00	C-2	1LX-22141-00	C-9	3JD-23126-L0	C-14
4JY-11166-00	B-2	4SS-12483-00	B-7	4PE-14261-00	B-9	4EX-17151-00	C-2	4EW-22151-01	C-9	4SS-23136-L0	C-13
4SS-11311-00	B-2	4SS-12484-00	B-7	4SS-14401-00	B-8	4EX-17161-00	C-2	4EW-22178-00	C-6	4SS-23136-L0	C-13
4SS-1131A-00	B-2	353-13115-01	B-12	4SS-14417-00	B-8	1LX-17211-01	C-2	3JD-22178-10	C-6	4SS-23138-01	C-15
4JY-1131E-00	B-2	4PE-13565-00	B-8	4SS-14451-00	B-8	3XJ-17221-00	C-2	4SS-2217A-00	C-9	4SS-2313C-01	C-15
4SS-1131M-00	B-2	4SS-13610-00	B-8	4SS-14453-00	B-8	3SR-17231-00	C-2	4SS-2217F-00	C-10	4SS-23141-10	E-2
4SS-1131V-00	B-2	4SS-13613-00	B-8	3JD-14458-00	B-8	4EX-17241-00	C-2	4EW-22199-01	C-9	4SS-23141-20	E-2
4SS-1132A-00	B-2	4JY-13616-00	B-8	3JD-14459-00	B-8	4EX-17251-00	C-2	4SS-22201-00	C-11	4SS-23141-30	E-2
4JY-11351-00	B-2	4SS-14101-00	B-9	3JD-14462-00	B-8	4EX-17261-00	C-2	4SS-22201-10	C-11	4SS-23141-40	E-2
4JY-11354-01	B-2	4PE-14103-00	B-9	3JD-14477-00	B-8	3XJ-17411-00	C-2	4SS-22201-20	C-11	4SS-23141-50	E-2
4SS-11400-00	B-5	3JD-14104-00	B-9	3JE-14561-00	B-9	3XJ-17421-00	C-2	4SS-22201-30	C-11	4SS-23141-60	E-2
4SS-11410-00	B-5	4PE-14107-38	B-9	1FN-14565-00	B-9	4SS-18101-00	C-5	4SS-22210-00	C-11	4SS-23141-70	E-2
4SS-11420-00	B-5	4SS-14112-45	B-10	4SS-14610-00	B-11	4SS-18110-00	C-5	4SS-22210-10	C-11	4SS-23141-L0	C-13
4JY-11611-00	B-5	4SS-14112-50	B-10	4JY-14615-00	B-11	3XJ-18122-00	C-5	4SS-22210-20	C-11	4SS-23141-L0	C-14
4JY-11611-00	E-3	4SS-14112-55	B-10	4JY-1469A-02	B-11	4JY-18140-00	C-4	4SS-22210-30	C-11	4SS-23142-L0	C-13
4SS-11630-00	E-3	3XK-14115-00	B-9	4SS-14753-00	B-11	4JY-18172-00	C-5	4JX-22212-10	E-2	4SS-23142-L0	C-14
4JY-11631-02-A0	B-5	5A0-14116-E0	B-9	4SS-14753-10	B-11	3XJ-18173-00	C-5	4JX-22212-20	C-11	4SS-23143-L0	C-13
4JY-11631-02-B0	B-5	5A0-14116-E1	B-9	565-14771-00	B-11	3XJ-18178-00	C-5	4JX-22212-20	E-2	4SS-23143-L0	C-14
4JY-11631-02-B0	E-3	5A0-14116-E2	B-9	256-14919-00	B-9	3XJ-18182-00	C-5	4JX-22212-30	E-2	4SS-23144-L0	C-13
4JY-11631-02-C0	B-5	5A0-14116-E3	B-9	4SS-15111-00	B-12	3XJ-18184-00	C-5	4JX-22212-40	E-2	4SS-23144-L0	C-14
4JY-11631-02-D0	B-5	5A0-14116-E4	B-9	4SS-15121-00	B-12	4EW-18185-00	C-5	4JX-22212-50	E-2	4SS-23145-L0	C-13
4PE-11633-00	B-5	4PE-14131-00	B-9	1RG-15363-00	B-13	4SS-18511-00	C-4	4JX-22212-60	E-2	4SS-23145-L0	C-14
4PE-11633-00	E-3	87M-14137-00	B-10	1LX-15383-00	C-2	2VN-18512-01	C-4	3SP-22213-00	C-11	4SS-23146-L0	C-13
4SS-11650-00	E-3	3TC-14141-S6	B-10	3XJ-15383-00	C-2	4SS-18513-00	C-4	3JD-22214-00	C-11	4SS-23146-L0	C-14
4PE-11651-01	B-5	3TC-14141-S7	B-10	4JY-15411-00	B-13	4EX-18531-00	C-4	4MX-22216-00	C-11	3JD-23147-L0	C-13
4PE-11651-01	E-3	3TC-14141-S8	B-10	4JY-15415-00	B-13	4EX-18535-00	C-4	3JD-22224-00	C-11	3JD-23147-L0	C-14
3JD-11681-01	B-5	3TC-14141-S9	B-10	4EX-15421-00	B-13	4JY-18540-00	C-4	4JX-22226-00	C-11	4SS-2314A-L0	C-13
3JD-11681-01	E-3	3TC-14141-T0	B-10	4JY-15431-00	B-13	4SS-21101-00-UJ	C-6	3SP-22234-00	C-11	4SS-2314A-L0	C-14
4SS-11832-00	B-2	4KM-14142-40	B-9	4JY-15451-00	B-13	4SS-21190-00-UJ	C-6	3SP-22241-00	C-11	4SS-2314E-00	D-5
5X5-11911-01	B-4	4KM-14142-45	B-9	4JY-15462-00	B-13	4SR-21190-00-UJ	C-6	3XJ-22253-00	C-11	4SS-2314F-L0	C-14
5X5-11912-01	B-4	4KM-14142-50	B-9	4JY-15463-00	B-13	1HX-2135F-10	C-10	4EW-22253-00	C-11	4SS-2314G-L0	C-14
4JY-11915-01	B-4	4KM-14142-55	B-9	4DB-15620-03	B-14	4SS-21425-00	C-6	43M-22274-00	C-11	4SS-2314H-00	C-15
5X4-11921-02	B-4	4KM-14142-60	B-10	4DB-15621-03	B-14	4DA-21511-00	C-7	4SS-22355-00	C-9	4SS-2314J-00	C-14
3JE-11922-01	B-4	4KM-14142-65	B-10	1LX-15641-00	B-14	4SS-21611-00	C-7	4EW-22474-00	C-11	4SS-23153-L0	C-13
5X4-11952-00	B-4	137-14143-66-A1	B-10	1LX-15651-00	B-14	4ES-21642-00	C-7	3JD-22475-00	C-11	3SP-23153-L0	C-13
24X-11953-01	B-4	137-14143-68	B-10	1LX-15660-02	B-14	4SS-21711-00	C-8	3JE-22475-00	C-11	4SS-23153-L0	C-14
4SS-11990-00	B-4	137-14143-70	B-10	3XJ-16111-00	B-15	4SS-21721-00	C-8	4GY-22898-50	D-8	3SP-23153-L0	C-14
4JY-11991-00	B-3	137-14143-72	B-10	4JY-16150-01	B-15	4EW-2172A-10	C-8	4SS-23102-L0	C-13	4SS-23158-L0	C-13

NUMERICAL INDEX

PART NO.	GRID NO.	PART NO.	GRID NO.	PART NO.	GRID NO.	PART NO.	GRID NO.	PART NO.	GRID NO.	PART NO.	GRID NO.
4SS-23158-L0	C-14	3SP-25388-00	D-6	4SS-26281-00	D-9	90110-05201	C-9	90201-065F3	C-7	90387-063G3	B-11
3SP-23166-L0	C-13	4SS-2538E-00	D-10	4SS-26282-01	D-9	90116-08318	B-2	90201-08087	B-2	90387-0700G	B-7
3SP-23166-L0	C-14	5X2-25394-00	D-4	4SS-26287-01	D-9	90116-08388	B-2	90201-080E2	C-6	90387-0701A	C-7
4SS-2316A-L0	C-13	2X3-25394-00	D-6	4SS-2628H-00	D-9	90116-08394	B-2	90201-08512	B-6	90387-085E1	B-4
4SS-2316A-L0	C-14	4SS-25447-00	D-6	4SS-26311-01	D-9	90119-06096	C-7	90201-086P8	C-6	90387-086N4	C-6
4SS-23170-L0	C-13	4SS-25448-00	D-6	4JY-26335-00	D-9	90119-06185	B-11	90201-086P8	D-6	90387-08785	B-3
4SS-23170-L0	C-14	4SS-25449-00	D-6	4SS-26372-00	D-10	90119-06185	C-12	90201-08730	C-6	90387-107R6	B-11
4SS-23171-L0	C-13	4SS-25450-00	D-6	4SS-27200-00	D-11	90119-06214	D-2	90201-08784	B-6	90387-107T9	B-4
4SS-23171-L0	C-14	4SS-25451-00	D-6	4SS-27217-00	D-11	90122-06035	B-8	90201-090J9	D-5	90387-152F2	B-4
3Y6-23183-00	C-11	4SS-25452-00	D-6	4SS-27222-00	D-12	90123-08090	D-14	90201-10118	D-10	90387-160H4	B-12
509-23184-L0	C-11	4MX-25718-00	D-8	4ES-27311-00	D-11	90149-06011	D-2	90201-10118	D-12	90387-164N2	C-9
4EW-2331E-L0	C-15	4SS-2580T-00	D-5	4DA-27411-00	D-11	90149-06011	D-13	90201-10119	B-15	90387-164N3	C-9
4SS-23340-L0	C-14	4MX-2580W-00	D-8	4DA-27421-00	D-11	90149-06272	D-5	90201-10119	D-11	90387-167Y9	C-9
4SS-23346-L0	C-14	4GY-25827-50	D-8	4GY-27491-00	D-8	90149-06272	D-8	90201-10774	D-13	90387-2000B	D-6
3SP-23356-L0	C-15	2VN-2582A-50	D-12	56A-28166-00	C-6	90151-04048	C-9	90201-14740	C-10	90387-2000C	D-6
3SP-23357-L0	C-13	4JX-2582T-00	D-5	4SS-82310-00	D-15	90151-06037	C-2	90201-152H7	B-14	90387-2007S	D-4
3SP-23357-L0	C-13	4MX-2582W-00	D-8	4PE-82370-00	D-15	90151-06037	C-2	90201-154E8	C-2	90387-2007T	D-4
3SP-23357-L0	C-14	4SS-25833-00	D-10	4SS-82509-00	D-15	90152-06010	B-14	90201-154E9	B-4	90387-2007U	D-4
4SS-23363-L0	C-13	4SS-25833-00	D-10	12R-82591-00	D-15	90159-06016	B-15	90201-164H4	C-9	90387-202A0	C-3
4SS-23363-L0	C-14	4SS-2583G-00	D-10	38V-82911-00	D-14	90159-06078	C-4	90201-164H4	C-10	90387-202T9	B-15
4SS-23364-L0	E-2	3SP-2583V-00	D-12	38V-82913-00	D-14	90159-06078	C-8	90201-171G4	B-14	90387-227H7	D-9
4DA-23389-00	C-12	4SS-25852-00	D-10	4GY-83912-00	D-14	90159-06078	C-8	90201-204K8	B-15	90401-10159	D-10
3SP-23393-L0	C-13	3XP-25852-50	D-12	4SS-83913-00	D-10	90159-06182	C-8	90201-206K8	C-2	90401-10159	D-12
3SP-23393-L0	C-14	4SS-25854-00	D-10	4SS-83922-00	D-10	90159-06182	C-8	90201-22555	C-2	90430-06014	B-6
4EW-23416-00	C-12	2VN-25854-00	D-12	437-83936-01	D-14	90170-16326	B-15	90201-247L2	C-12	90430-06014	B-13
4SS-23435-00	C-12	2VN-25855-00	D-12	25G-83936-01	D-15	90170-24373	C-12	90201-286K9	C-12	90430-06014	B-15
3SP-23441-00	C-12	4SS-25866-00	D-10	23X-83976-00	D-14	90176-08026	B-2	90202-05187	D-2	90430-12227	B-12
4DA-23485-01	C-12	2VN-25866-00	D-12	4SS-85540-00	D-15	90179-06568	C-9	90209-06096	B-8	90445-08605	B-12
4SS-24110-00	D-2	3YX-25866-10	D-10	4SS-85546-00	D-15	90179-08401	D-14	90209-18135	C-2	90445-09252	D-2
4EW-2412F-00	D-2	3YK-25867-00	D-10	4SS-85546-00	D-15	90179-08491	B-2	90209-18208	C-2	90445-114J7	D-2
24X-24144-00	D-2	4SS-25868-00	D-10	4SS-85550-00	D-13	90179-16226	C-3	90209-22248	B-5	90445-137H9	D-12
3SP-24173-00	D-2	4SS-25872-00	D-10	4SS-85560-00	D-13	90179-16672	D-4	90209-22248	E-3	90450-22052	B-7
4SS-24181-00	D-2	4SS-25873-00	D-12	4SS-W2587-00	D-10	90179-16672	C-12	90215-16289	B-15	90450-25037	B-7
4SS-24182-00	D-2	2VM-25876-00	D-12	90101-06664	C-5	90179-28650	B-8	90215-20261	C-3	90450-28014	B-7
3JD-24186-00	D-2	4SS-25880-00	D-10	90101-08777	D-6	90183-06023	C-7	90240-08120	D-11	90450-51070	B-8
3JD-24500-01	D-2	4SS-25889-00	D-10	90105-05361	C-12	90183-06023	C-8	90240-10117	D-11	90450-70072	B-8
4X8-24512-00	D-2	4EW-25894-00	D-12	90105-06553	B-8	90183-06069	C-8	90267-32119	B-8	90464-14117	D-2
3AJ-24534-00	D-2	4SS-2589F-00	D-10	90105-08099	C-6	90185-14070	C-10	90280-03017	C-9	90464-14117	D-15
1UY-24610-00	D-2	3SP-25919-01	D-5	90105-08659	D-5	90185-16127	D-6	90338-16148	C-6	90465-08336	B-12
4SS-24728-00	D-3	4GY-25919-50	D-8	90105-10445	B-15	90185-18104	B-8	90338-16148	C-9	90465-16258	D-10
4SS-24731-00	D-3	3SP-25924-51	D-8	90105-10614	C-11	90201-03644	B-2	90340-12097	B-12	90467-09006	B-7
4SS-24770-00	D-3	3GD-25933-00	D-5	90105-10733	C-6	90201-057H5	B-4	90380-16158	C-9	90467-10008	D-2
4DA-25104-00	D-4	4JX-26111-00	D-9	90106-08051	C-6	90201-057H5	C-7	90387-0600F	C-7	90467-11044	D-12
4SS-25111-00	D-4	4SS-26241-00	D-9	90109-06418	B-15	90201-06071	B-8	90387-0600F	C-8	90467-13062	B-2
4SS-25181-00	D-4	4SS-26242-00	D-9	90109-06799	D-14	90201-061A5	B-7	90387-0600F	C-8	90467-21068	B-7
3JD-25304-00	D-6	4SS-26243-00	D-9	90109-08066	D-5	90201-063J2	B-11	90387-062W7	B-11	90468-16191	D-11
4EW-25311-00	D-6	4SS-26259-00	D-9	90109-08161	D-6	90201-063J2	B-11	90387-063F7	C-4	90468-26048	B-14
4V4-25367-00	D-7	4SS-26273-00	D-9	90109-142F4	C-9	90201-065F3	B-14	90387-063G3	B-11	90480-10068	D-6
3JD-25381-01	D-6	4SS-2627A-00	D-9	90109-147F2	C-9	90201-065F3	B-14				

NUMERICAL INDEX

PART NO.	GRID NO.	PART NO.	GRID NO.	PART NO.	GRID NO.	PART NO.	GRID NO.	PART NO.	GRID NO.	PART NO.	GRID NO.
90480-10289	B-11	93104-08040	B-4	93604-18100	B-2	95317-10600	D-13				
90480-15528	B-7	93106-22019	C-9	9383A-12017	C-3	95337-08600	D-12				
90480-16561	B-11	93106-28023	D-6	9383A-13031	C-3	95617-05100	B-8				
90480-16561	B-11	93109-12012	C-5	9383A-14054	C-3	95617-06100	D-10				
90480-18549	D-2	93109-20029	C-9	94108-2102V	D-4	95617-06100	D-14				
90501-05265	C-5	93109-20029	C-10	94108-217X2	D-4	95617-08100	D-6				
90501-12081	B-14	93210-11073	D-11	94110-1900X	D-6	95617-08200	C-6				
90501-23391	B-15	93210-15171	B-14	94110-1902X	D-6	95617-08200	C-6				
90501-30742	B-4	93210-15620	D-12	94210-19224	D-6	95617-10200	C-6				
90506-16500	D-11	93210-19123	B-13	94227-21123	D-4	95617-10200	C-11				
90507-20052	B-11	93210-42728	B-11	94307-21145	D-4	95707-08500	C-6				
90508-147A7	B-3	93210-63442	B-2	94327-19111	D-6	95707-08500	D-6				
90508-26450	B-14	93210-90785	B-2	94416-21547	D-4	95817-06012	D-5				
90508-26691	C-4	93300-60804	C-6	94418-19537	D-6	95817-06016	C-8				
90508-28777	D-11	93300-60814	B-4	94681-65001	D-7	95817-06016	C-8				
90508-295A7	C-5	93306-00418	D-6	94702-00324	B-2	95817-06016	C-8				
90560-08213	B-4	93306-20469	C-2	94702-00325	B-2	95817-06016	C-8				
90560-12280	C-5	93306-30411	C-2	94703-00325	B-2	95817-08050	C-6				
90560-17279	B-14	93306-37204	B-5	95024-08040	C-14	95817-08090	C-6				
90560-20278	D-6	93306-90403	D-4	95027-06010	B-6	97007-05012	B-4				
91317-04006	B-4	93310-216L2	B-5	95027-06010	B-13	97007-05016	B-3				
91317-04008	B-2	93310-216L2	E-3	95027-06010	C-9	97007-05016	D-14				
91317-06014	D-10	93310-225N0	B-15	95027-06012	B-11	97027-06012	B-14				
91317-06016	D-15	93310-522P7	B-5	95027-06012	C-7	97027-06012	D-3				
91317-06045	B-12	93310-522P7	E-3	95027-06012	D-8	97707-60016	C-7				
91317-06055	B-12	93311-31567	C-3	95027-06012	D-12	97780-50110	D-12				
91317-06070	B-12	93311-41530	C-2	95027-06016	B-11	98507-03008	B-8				
91401-25020	D-11	93315-11206	B-15	95027-06016	D-2	98507-04008	B-9				
91490-20025	D-11	93315-22046	C-9	95027-06016	D-8	98507-05012	B-4				
91A20-05080	B-7	93315-22046	C-10	95027-06020	B-8	98507-06016	B-13				
92014-06016	D-12	93317-22262	C-9	95027-06020	C-5	98517-04012	B-9				
92017-06010	B-11	93332-00078	C-12	95027-06020	C-7	98517-06030	B-13				
92907-03200	B-8	93332-00081	C-12	95027-06025	B-11	98580-03008	D-2				
92907-05600	B-3	93340-21505	B-4	95027-06025	B-13	98707-04010	D-9				
92907-06100	D-3	93342-21013	B-15	95027-06025	D-9	98707-04012	D-10				
92907-06600	B-13	93342-22215	C-9	95027-06030	B-6	98707-04018	D-9				
92907-08200	D-5	93410-22039	C-2	95027-06030	B-7	98707-06025	D-2				
92907-18600	D-7	93410-22039	C-2	95027-06030	B-13	98907-05010	B-2				
92990-03100	B-8	93440-15012	B-14	95027-06030	C-7	98907-05016	B-2				
92990-08600	D-11	93440-15012	C-2	95027-06040	B-13	98907-06020	D-2				
93102-12224	B-15	93450-17129	B-5	95027-06045	B-11	99009-10400	B-15				
93102-17263	B-14	93450-17129	E-3	95027-06045	C-9	99080-07600	B-6				
93102-22363	B-5	93507-32031	B-14	95027-06065	B-6	99241-00160	C-15				
93102-25360	D-4	93521-64032	B-4	95027-08020	D-5	99510-10114	B-2				
93102-26042	C-2	93603-14179	B-4	95027-08035	C-12	99510-12016	B-12				
93103-10168	B-6	93603-22028	B-6	95027-08040	C-6	99530-10014	B-13				
93103-32099	B-5	93604-10011	B-6	95027-08040	C-12	9Y581-65111	D-7				
93104-08040	B-2	93604-10011	B-13	95027-08065	C-6						